

Drive^{IT} Low and High Voltage Process Performance Motors

LV Cast Iron Motors Section



Industrial^{IT}
enabled

ABB

Making you more competitive

ABB's Process performance motor is engineered to the toughest demands of today's process industries. These motors use the best materials and construction methods to achieve the highest quality and reliability, and a possible operating life of over 30 years. The motor design is highly adaptable to allow rapid engineered solution according to customer's specification.

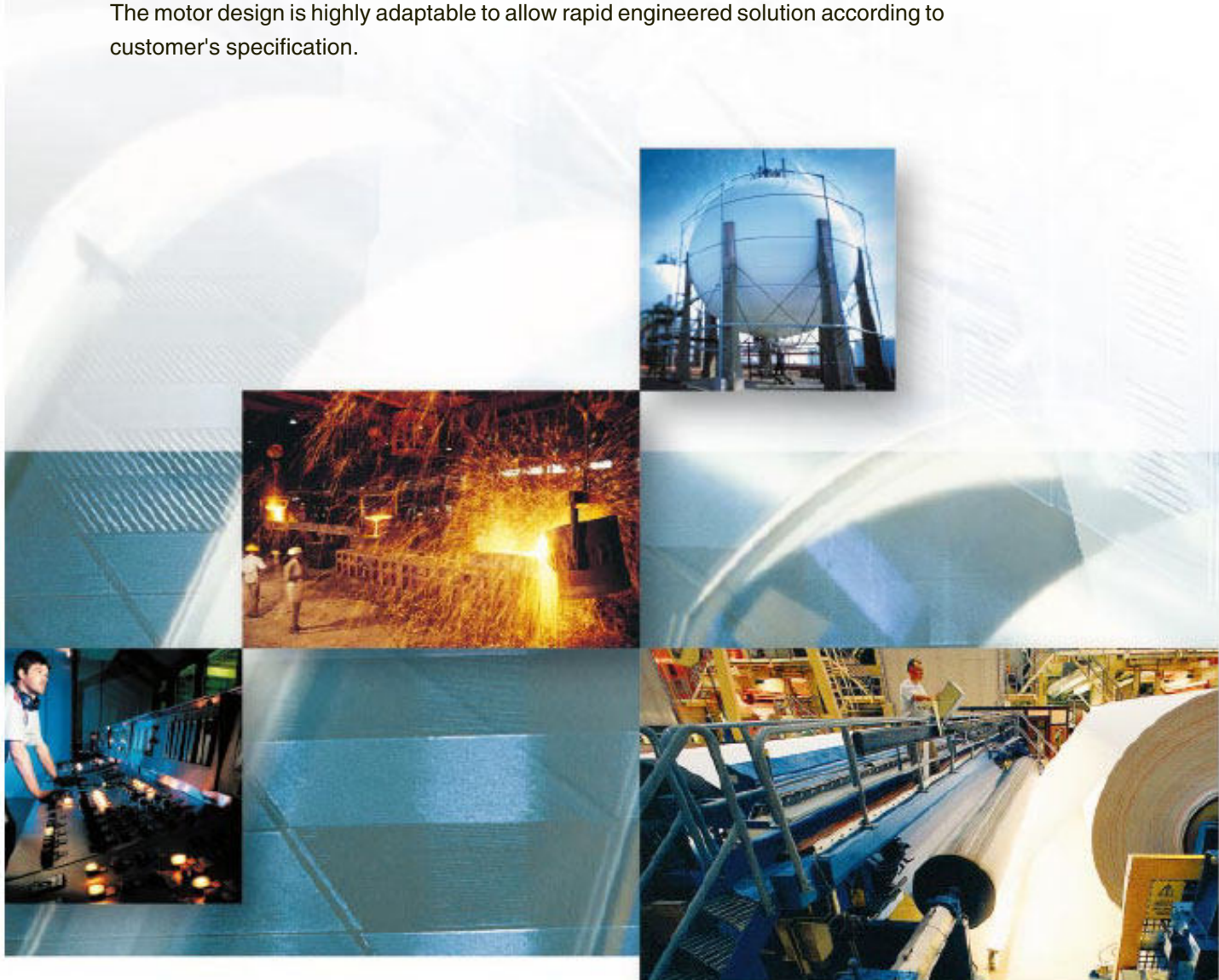

Industrial^{IT}

As a key element of its business strategy, ABB has committed to a broad program of product development and positioning under the Industrial^{IT} umbrella. This initiative is geared towards increasing standardization of ABB products as the 'building blocks' of larger solutions, while incorporating functionality that will allow multiple products to interact seamlessly as components of real-time automation and information systems.

Motors and generators represent one of the fundamental building blocks in the Industrial^{IT} architecture.

ABB (www.abb.com) is a leader in power and automation technologies that enable utility and industry customers to improve performance while lowering environmental impacts. The ABB Group of companies operates in around 100 countries and employs around 115,000 people.

Drive^{IT} Low and High Voltage Process Performance Motors

Sizes 71 to 400, from 0.25 to 710 kW

Contents

Page

1	General information	4
2	Low voltage cast iron motors	13
3	Low voltage aluminum motors	67
4	High voltage cast iron motors	115

ABB reserves the right to change the design, technical specification and dimensions without prior notice.

General information

Standards

ABB motors are of the totally enclosed, three phase squirrel cage type, built to comply with international IEC and EN standards. Motors conforming to other national and international specifications are also available on request.

All production units are certified to ISO 9001 international quality standard as well ISO 14000 environmental standard and confirm to all applicable EU Directives.

IEC / EN

Electrical	Mechanical
IEC/EN 60034-1	IEC 60072
IEC/EN 60034-2	IEC/EN 60034-5
IEC 60034-8	IEC/EN 60034-6
IEC 60034-12 (for LV only)	IEC/EN 60034-7
	IEC/EN 60034-9
	IEC 60034-14

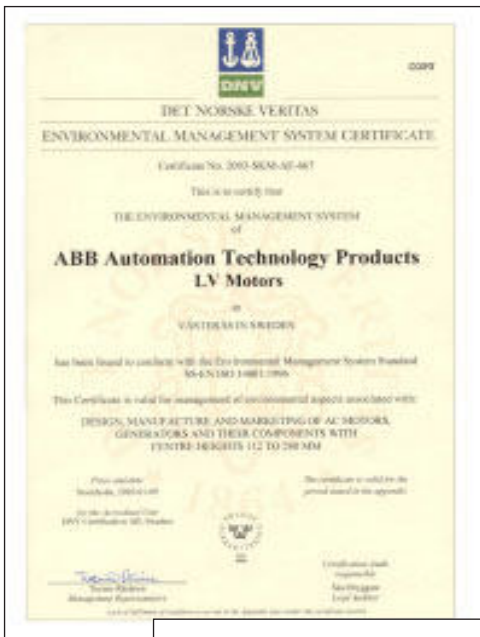

Low voltage motors for EU motor efficiency levels

A Europe-wide agreement will ensure that the efficiency levels of electric motors manufactured in Europe are clearly displayed. In contrast to the American legislation on motor efficiency the European agreement does not establish mandatory efficiency levels.

It basically establishes three classes giving motor manufacturers an incentive to qualify for a higher class.

ABB is one of only a handful of leading motor manufacturers in Europe to have a motor range to meet or exceed the minimum efficiencies stated in the highest level of the EU agreement of low voltage motors.

These efficiency levels apply to 2- and 4-pole, three phase squirrel cage induction motors rated for 400 V,

50 Hz with S1 duty class with the output 1.1 to 90 kW, which account for the largest volume on the market.

The efficiency of motors from different manufacturers are collated in a database, EURODEEM, published by the European Commission. It is accessible over the Internet at <http://iamest.jrc.it/projects/eem/eurodeem.htm>.

EU efficiency classes for 2-pole motors

Output kW	2-pole Boarderline	
	EFF2/EFF3	EFF1/EFF2
1.1	76.2	82.8
1.5	78.5	84.1
2.2	81.0	85.6
3	82.6	86.7
4	84.2	87.6
5.5	85.7	88.6
7.5	87.0	89.5
11	88.4	90.5
15	89.4	91.3
18.5	90.0	91.8
22	90.5	92.2
30	91.4	92.9
37	92.0	93.3
45	92.5	93.7
55	93.0	94.0
75	93.6	94.6
90	93.9	95.0

EU efficiency classes for 4-pole motors

Output kW	4-pole Boarderline	
	EFF2/EFF3	EFF1/EFF2
1.1	76.2	83.8
1.5	78.5	85.0
2.2	81.0	86.4
3	82.6	87.4
4	84.2	88.3
5.5	85.7	89.2
7.5	87.0	90.1
11	88.4	91.0
15	89.4	91.8
18.5	90.0	92.2
22	90.5	92.6
30	91.4	93.2
37	92.0	93.6
45	92.5	93.9
55	93.0	94.2
75	93.6	94.7
90	93.9	95.0



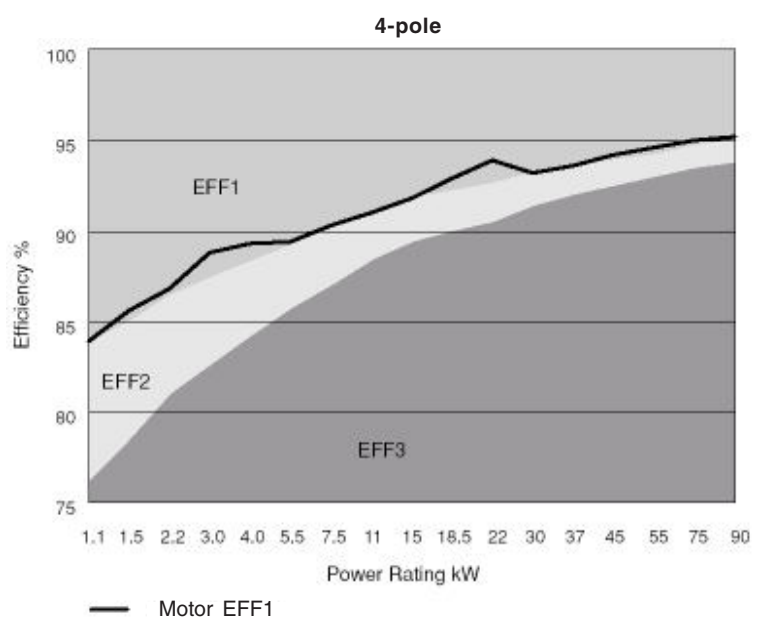
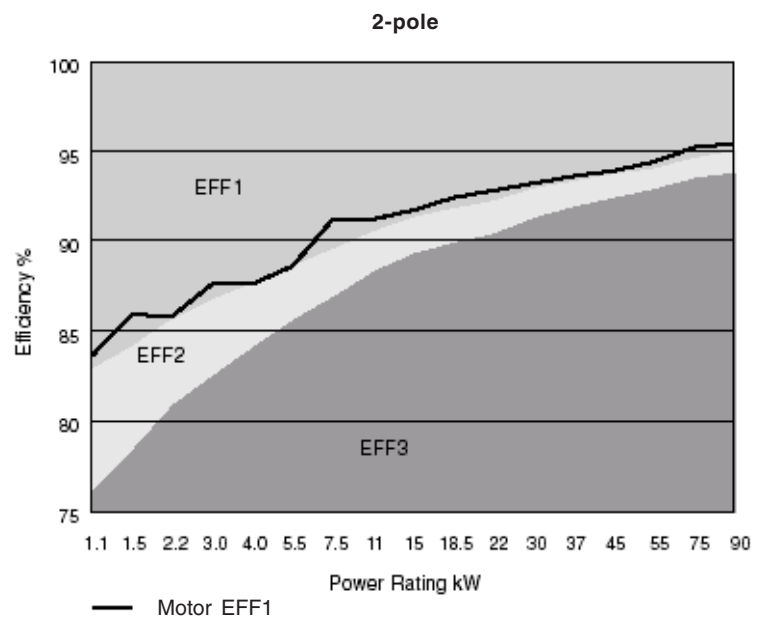







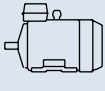



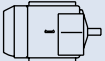
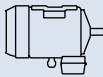
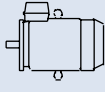

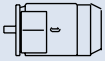
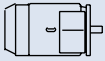
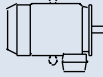
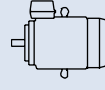
ABB three phase induction motors, 400 V
50 Hz - EU motor efficiency levels

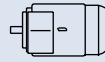
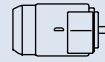
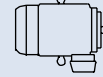
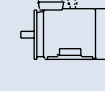

General technical specification

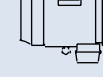
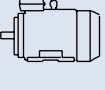
Mechanical and electrical design

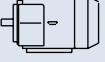
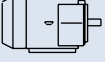
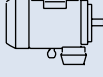
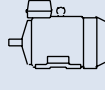
Mounting arrangements

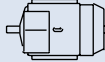
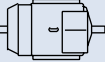
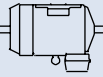
	Code I/Code II						Product code pos. 12
Foot-mounted motor.	IM B3 IM 1001	IM V5 IM 1011	IM V6 IM 1031	IM B6 IM 1051	IM B7 IM 1061	IM B8 IM 1071	A = foot-mounted, term.box top R = foot-mounted, term.box RHS L = foot-mounted, term.box LHS
							
Flange-mounted motor, large flange	IM B5 IM 3001	IM V1 IM 3011	IM V3 IM 3031	*) IM 3051	*) IM 3061	*) IM 3071	B = flange mounted, large flange
							
Flange-mounted motor, small flange	IM B14 IM 3601	IM V18 IM 3611	IM V19 IM 3631	*) IM 3651	*) IM 3661	*) IM 3671	C = flange mounted, small flange
							
Foot- and flange-mounted motor with feet, large flange	IM B35 IM 2001	IM V15 IM 2011	IM V36 IM 2031	*) IM 2051	*) IM 2061	*) IM 2071	H = foot/flange-mounted, term.box top S = foot/flange-mounted, term.box RHS T = foot/flange-mounted, term.box LHS
							
Foot- and flange-mounted motor with feet, small flange	IM B34 IM 2101	IM 2111	IM 2131	IM 2151	IM 2161	IM 2171	J = foot/flange-mounted, small flange
							
Foot-mounted motor, shaft with free extensions	IM 1002	IM 1012	IM 1032	IM 1052	IM 1062	IM 1072	
							

*) Not stated in IEC 60034-7.

Cooling

Designation system concerning methods of cooling refers to standard IEC 60034-6.

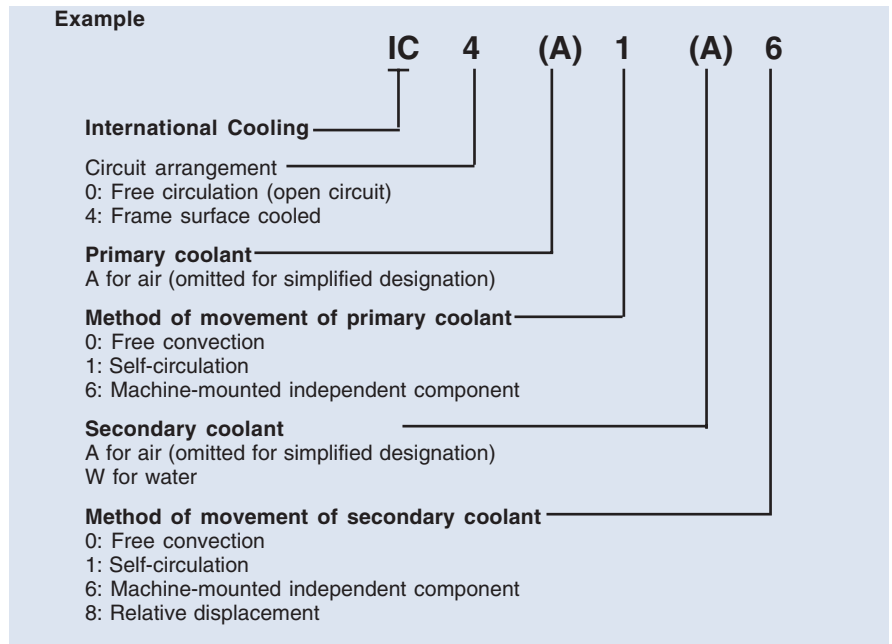

Degrees of protection: IP code/IK code

Classification of degrees of protection provided by enclosures of rotating machines are refers to:

- Standard IEC 60034-5 or EN 60529 for IP code
- Standard EN 50102 for IK code

IP protection:

Protection of persons against getting in contact with (or approaching) live parts and against contact with moving parts inside the enclosure.

Also protection of the machine against ingress of solid foreign objects. Protection of machines against the harmful effects due to the ingress of water

IK code :

Classification of degrees of protection provided by enclosure for motors against external mechanical impacts.

IP 5 5

Characteristic letter ————|

Degree of protection to persons and to parts of the motors inside the enclosure ————|

2: Motors protected against solid objects greater than 12 mm
 4: Motors protected against solid objects greater than 1 mm
 5: Dust-protected motors

Degree of protection provided by the enclosure with respect to harmful effects due to ingress of water ————|

3: Motors protected against spraying water
 4: Motors protected against splashing water
 5: Motors protected against water jets
 6: Motors protected against heavy seas

IK 08

International mechanical protection ————|

Characteristic group ————|

Relation between IK code and impact energy:

IK cod	IK 0	IK 01	IK 02	IK 03	IK 04	IK 05	IK 06	IK 07	IK 08	IK 09	IK 10
Impact energy Joule	*	0.15	0.2	0.35	0.5	0.7	1	2	5	10	20
									ABB Standard		

* not protected according to EN 50102



Insulation

ABB uses class F insulation systems, which, with temperature rise B, is the most common requirement among industry today.

The use of Class F insulation with Class B temperature rise gives ABB products a 25° C safety margin. This can be used to increase the loading by up to 12 per cent for limited periods, to operate at higher ambient temperatures or altitudes, or with greater voltage and frequency tolerances. It can also be used to extend insulation life. For instance, a 10 K temperature reduction will extend the insulation life.

Class F insulation system

- Max ambient temperature 40° C
- Max permissible temperature rise 105 K
- Hotspot temperature margin + 10 K

Class B rise

- Max ambient temperature 40° C
- Max permissible temperature rise 80 K
- Hotspot temperature margin + 10 K

Insulation system temperature class

- Class F 155° C
- Class B 130° C
- Class H 180° C

1

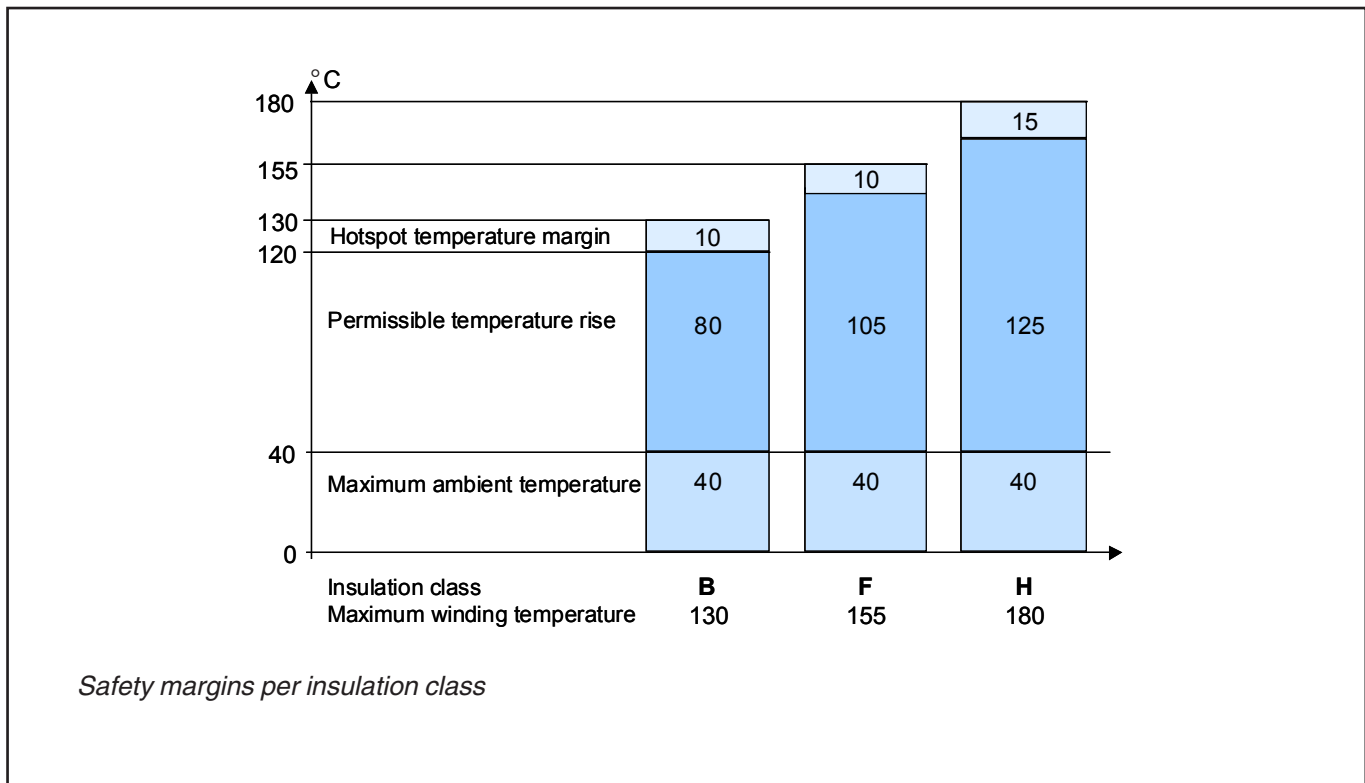

All ABB high voltage motors are made with form wound windings with Micadur® Compact Industry Insulation System (class F). For more information, please see the brochure Micadur® -Compact Industry, Insulation System for Rotating Electrical Machines (code 3BFP 001 980 R0101 REV B 06/2003).

Frequency converter drives for low voltage motors

Squirrel cage induction motors offer excellent availability, reliability and efficiency. With a frequency converter – a variable speed drive (VSD) – the motor will deliver even better value. A variable speed drive motor can be started softly with low starting current, and the speed can be controlled and adjusted to suit the application demand without steps over a wide range. Also the use of a frequency converter together with a squirrel cage motor usually leads to remarkable energy and environmental savings.

Process performance motors manufactured by ABB are designed for both, variable speed and direct on line use. Also a wide range of options is available to fit the motors even to the most demanding applications.

When selecting process performance motors to variable speed drives, followings points shall be taken into consideration:

1. Dimensioning

The voltage (or current) fed by the frequency converter is not purely sinusoidal. This may increase the losses, vibration, and noise of the motor. Furthermore, a change in the distribution of the losses may affect the motor temperature balance and lead to an increase in the temperature of the bearings. In each case, the motor must be correctly sized according to the instructions supplied with the selected frequency converter.

When using ABB converters, please use ABB's DriveSize dimensioning programme or the loadability curves of the corresponding converter type for sizing the motors. The loadability curve of a process performance motor used with ABB's ACS 600- and ACS 800 -frequency converters can be found in figure 3.

2. Speed range

In a frequency converter drive, the actual operating speed of the motor may deviate considerably from its nominal speed (i.e. the speed stamped on the rating plate).

For higher speeds, ensure that the highest permissible rotational speed of the motor or the critical speed of the entire equipment is not exceeded. When high speed operation exceeds the nominal speed of the motor, the following points should be checked:

- Maximum torque of the motor
- Bearing construction
- Lubrication
- Balancing
- Critical speeds
- Shaft seals
- Ventilation
- Fan noise

Guideline values of maximum speeds for process performance motors are described in figures 1a and 1b. Exact values can be found from the product specific sections of this catalogue or from the rating plate of the motor.

Figure 1a. Guide line values of maximum speeds for process performance cast iron motors

Frame size	Speed r/min	
	2-pole	4-pole
71 – 200	4000	3600
225 – 280	3600	2600
315	3600	2300
355	3600	2000
400	3600	1800

Figure 1b. Guide line values of maximum speeds for process performance aluminum motors

Frame size	Speed r/min	
	2-pole	4-pole
112 – 200	4500	4500
225 – 280	3600	3600

At low speed operation the motor's ventilation fan loses its cooling capacity, which causes a higher temperature rise in the motor and in the bearings. A separate constant speed fan can be used to increase cooling capacity and loadability at low speed. It is also important to check the performance of the lubrication at low speeds.

3. Lubrication

The effectiveness of the motor lubrication should be checked by measuring the bearing temperature under normal operating conditions. If the measured temperature is higher than +80°C, the relubrication intervals specified in ABB's Low Voltage Motors Manual must be shortened; i.e. the relubrication interval should be halved for every 15 K increase in bearing temperature. If this is not possible ABB recommends the use of lubricants suitable for high operating temperature conditions. These lubricants allow a normal relubrication interval and a 15 K increase in bearing temperature conditions.

At continuous operation on very low speeds as well as at very low temperatures the lubrication capabilities of standard greases may not be sufficient and special greases with additives are needed. For more information, please contact ABB.

If the motors are equipped with sealed bearings i.e. bearings greased for life, it shall be noted that when the operating temperature differs from the designed, also the lifetime of the bearing will differ from the original. More information about the lifetime of the bearings can be found from the product specific sections of this manual.

The use of so called conductive greases for elimination of bearing currents is not recommended due to their poor lubrication characteristics and low conductivity.

4. Insulation protection

Most of the modern low voltage frequency converters have IGBT power components with very rapid switching, steep voltage pulses and reflections at the cables. Those increase voltage stresses at the winding of the motor and therefore, the precautions described in figure 2 below must be taken to avoid risks of insulation damage.

For GTO converters, consideration must be given to the information about cable length, pulse rise time and the voltage overshoot using the voltage/cable length guideline.

5. Bearing currents

Bearing voltages and currents must be avoided in all motors. Assuming the use of a standard ABB Single drive, with IGBT components and a 6-pulse diode supply unit, insulated bearings and/or properly dimensioned filters at the converter output must be used according to the instructions in figure 2 below. (For other alternatives and converter types, please contact ABB.) When ordering, clearly state which alternative will be used.

For more information about bearing currents and voltages, please contact ABB.

6. Cabling, grounding and EMC

The use of a frequency converter sets higher demands on the cabling and grounding of the drive system. The motor must be cabled by using shielded symmetrical cables and cable glands providing 360° bonding (also called EMC-glands). For motors up to 30 kW unsymmetrical cables can be used, but shielded cables are always recommended, especially if there are sensitive sensors in the driven application.

For motors in frame size IEC 280 and upward, additional potential equalisation between the motor frame and the machinery is needed, unless they are installed on a common steel fundament. When a steel fundament is used for the potential equalisation, the high frequency conductivity of this connection should be checked.

More information about grounding and cabling of a variable speed drive can be found from the manual "Grounding and cabling of the drive system" (Code: 3AFY 61201998 R0125 REV A)

For fulfilling the EMC requirements, special EMC cable(s) must be used in addition to the correct cable gland mounting, with special, extra earthing pieces. Please refer to the manuals of the frequency converter.

Figure 2. Selection rules for insulation and filtering in variable speed drives

	Motor nominal power P_N or frame size		
	$P_N < 100 \text{ kW}$	$P_N \geq 100 \text{ kW or } \geq \text{IEC 315}$	$P_N \geq 350 \text{ kW } \geq \text{IEC 400}$
$U_N \leq 500 \text{ V}$	Standard motor	Standard motor + Insulated N-bearing	Standard motor + Insulated N-bearing + Common mode filter
$U_N \leq 600 \text{ V}$	Standard motor + dU/dt-filter OR Reinforced insulation	Standard motor + dU/dt-filter (reactor) + Insulated N-bearing OR Reinforced insulation + Insulated N-bearing	Standard motor + Insulated N-bearing + dU/dt-filter + Light Common mode filter OR Reinforced insulation + Insulated N-bearing + Common mode filter
$U_N \leq 690 \text{ V}$	Reinforced insulation + dU/dt-filter	Reinforced insulation + dU/dt-filter (reactor) + Insulated N-bearing	Reinforced insulation + Insulated N-bearing + dU/dt-filter + Light common mode filter

dU/dt filter (reactor)

Series reactor. DU/dt -filter decreases the changing rate of the phase and main voltages and thus reduces voltage stresses in the windings. DU/dt -filters also decrease so-called common mode currents and the risk of bearing currents. DU/dt -filters are designed so that dU/dt -rate of main voltages at motor terminals is less than 1 kV/s. See ABB manual, ACS 600 dU/dt -filter selection guide.

Common mode and light common mode filters

Common mode filters are made of toroidal cores installed around motor cables. These filters reduce so-called common mode

currents in VSD applications and thus decrease the risk of bearing currents. Common mode filters do not significantly affect the phase or main voltages on the motor terminals.

Insulated Bearings

Bearings with insulated inner or outer races are used as the standard solution. So-called hybrid bearings, i.e. bearings with non-conductive ceramic balls, can also be used in special applications. More information for spare part selection is available on request.

Validity

Measures mentioned in Figure 2 apply to Process performance motors with a single drive, based on IGBT components, using 6-pulse diode supply unit and manufactured by ABB. For other alternatives and converter types, please contact ABB.

Motor loadability with ACS 600/800 -frequency converter

The loadability curve in figure 3 below is a guideline curve for standard ACS 600 and ACS 800 drives, for exact values please contact ABB. It is possible to use the loadability curve also for other frequency converters, but it shall be noted that the harmonic content and control algorithms varies between different frequency converters and thus the temperature rise of the motor also differs.

These guidelines present the maximum continuous load torque of a motor as a function of frequency (speed) to give the same temperature rise as with rated sinusoidal supply at nominal frequency and full rated load.

The temperature rise of squirrel cage motors manufactured by ABB is normally class B. However, if the ABB catalogue indicates that class F temperature rise is utilised on a sinusoidal supply, the dimensioning of the motor at frequency converter supply should be done according to the temperature rise class B loadability curve.

If the motor is utilised according to the loadability curve temperature rise class F, the temperature rise in other parts of the motor should be noted and the lubrication intervals and type of grease checked.

For further information, please contact ABB.

Figure 3. Motor loadability with ACS 600, Field weakening point 50 Hz.

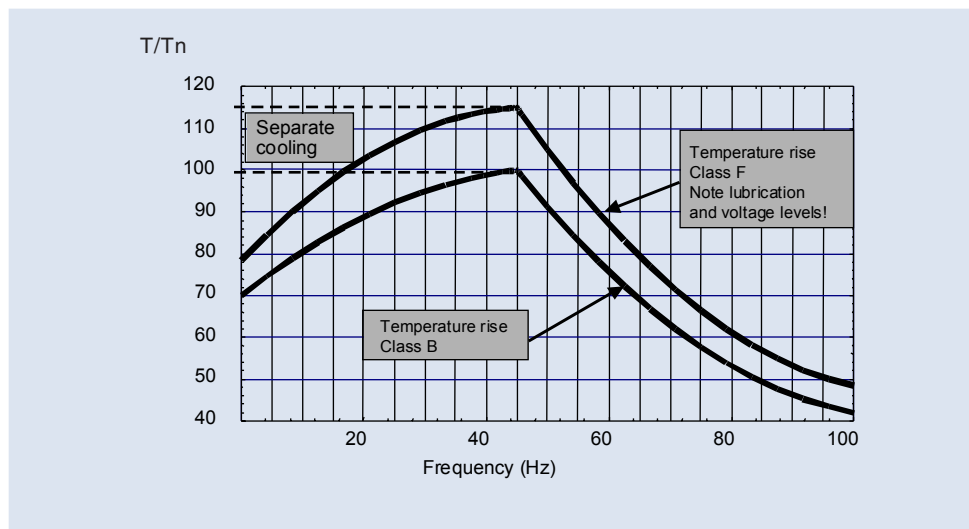

Frequency converter drives for high voltage motors

High voltage, M3BM, motors are suitable for ABB ACS 1000 series' converters or equivalent with sinusoidal output, quadratic load torque (pump, fan).

For more information, please contact your local ABB Sales office.

Drive^{IT} Low Voltage Process Performance Cast Iron Motors

Totally enclosed squirrel cage three phase low voltage motors,
Sizes 71 - 400, 0.25 to 710 kW



2

Mechanical design.....	14
Rating plates.....	24
Ordering information.....	25
Technical data.....	26
Variant codes.....	40
Dimension drawings.....	46
Accessories.....	60
Construction.....	64
Cast iron motors in brief.....	65

Mechanical design

Stator

The motor frames including feet, bearing housing and terminal box are made of cast iron. Integrally cast feet allow a very rigid mounting and minimal vibration.

Motors can be supplied for foot mounting, flange mounting and combinations of these.

Drain holes

Motors that will be operated in very humid or wet environments, and especially under intermittent duty, should be provided with drain holes. The appropriate IM designation, such as IM 3031, is specified, on the basis of the method of motor mounting.

In the basic design, sizes 71 to 132 are supplied without drain holes, although these can be provided as an option.

Motor sizes 160 to 400 are fitted with drain holes and closable plugs. The plugs are open on delivery. When mounting the motors, ensure that the drain holes face downwards.

In the case of vertical mounting, the upper plug must be hammered home completely. In very dusty environments, both plugs should be hammered home.

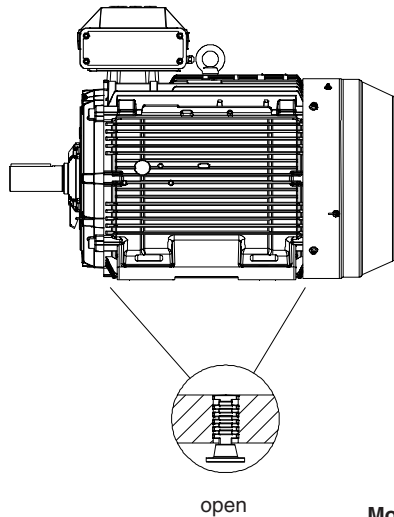

open

Motor sizes 71-132

As standard without drain holes.

Motor sizes 160-400

As standard with drain holes and closable plugs.

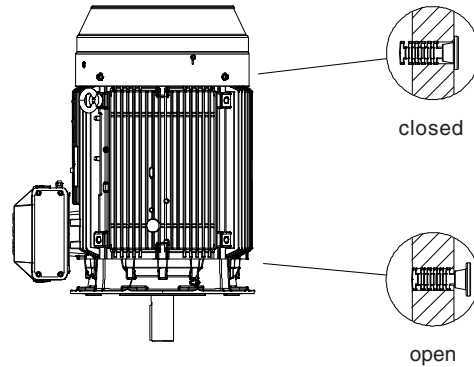

closed

open

Terminal box

Terminal boxes are mounted on the top of the motor as standard. The terminal box can also be mounted on the left or right side, see ordering information.

The terminal boxes can be turned 4x90°, to allow cable entry from any side of the motor.

Degree of protection of standard terminal box is IP 55.

Motor sizes 71 to 132 come with cable entries tapped in the terminal box frame, and can be provided with cable glands as an option.

Motor sizes 160 to 250 come with connection flanges with tapped cable entries, and can be provided with cable glands as an option.

In **motor sizes 280 to 400** the terminal box is equipped with cable glands or cable boxes as standard, see following pages.

If no ordering information on the cable is given, it is assumed to be p.v.c. -insulated and termination parts are supplied according to the table on the following pages.

To enable the supply of suitable terminations for the motor, please state cable type, quantity and size when ordering. Non-standard design of terminal boxes; e.g. size, degree of protection, are available as options.

Terminations are suitable for Cu- and Al-cables (Al-cables on request for motor sizes 71 to 250). Cables are connected to the terminals by cable lugs which are not included with the motor.

Please see variant code pages for options dimension drawings for terminal boxes can also be found after the motor drawings.

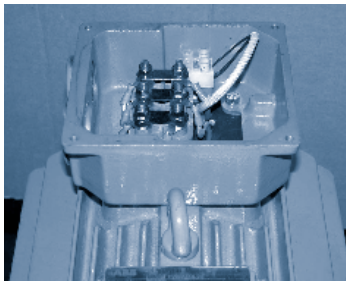

Terminal box for motor sizes 71 to 132

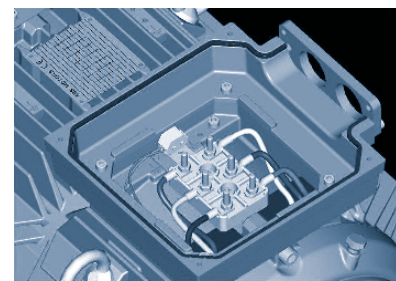

Terminal box for motor sizes 160 to 250

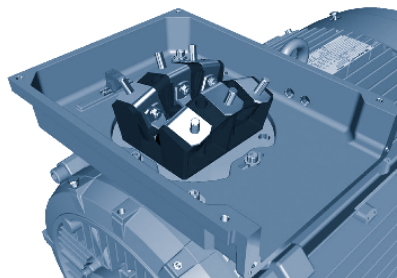

Terminal box for motor sizes 280 to 400, provided either with a cable gland or a cable box.

2

Co-ordination of terminal boxes and cable entries

If no ordering information on the cable is given, it is assumed to be p.v.c. -insulated and termination parts are supplied according to the following tables. These are supplied when using variant code '230 Standard cable glands' when ordering.

In **motor sizes 280 to 400** the terminal box is equipped with cable glands or cable boxes as standard according to the tables on the following pages. The table on next page shows the different alternatives available for cable boxes and cable entries. Other types on request.

Voltage 220 - 690 V, 50 Hz

Motor size	Terminal box	Flange opening	Main metric cable entry	Auxiliary cable entries	Cable gland diameter mm	Max. connection cable area, mm ²	Max. rated current A (D/Y conn.)	Terminal bolt size
71	–		2 x M16		Ø5-10	1 x 6		M4
80-90	–		2 x M25		Ø8-13	1 x 6		M4
100-132	–		2 x M32		Ø15-20	1 x 16		M5
160 -180	–		2 x M40	1 x M16 x 1.5	Ø19-27	1 x 35	63	M6
200 -250	–		2 x M63	1 x M16 x 1.5	Ø34-45	1 x 70	160	M10

Motor sizes 280-400 – Co-ordination of terminal boxes and cable entries

Motor size	Voltage/freq. code	Terminal box	Top-mounted Flange or adapter	Side-mounted Flange or adapter	Cable box or cable gland	Gland thread	Cable diameter	Max. connection cable area mm ²
------------	--------------------	--------------	-------------------------------	--------------------------------	--------------------------	--------------	----------------	--

3000 r/min (2 poles)

280		210	3GZF294730-749	3GZF294730-749	2x 3GZF294730-613	2x M63x1.5	2x Ø32-49	2x150
315SM, ML		370	3GZF294730-753	3GZF294730-753	2x 3GZF294730-613	2x M63x1.5	2x Ø32-49	2x240
315LKA, LKB		370	3GZF294730-753	3GZF294730-753	2x 3GZF294730-613	2x M63x1.5	2x Ø32-49	2x240
315LKC		750	3GZF294730-944	3GZF294730-759	3GZF294730-301		2x Ø48-60	4x240
355 SMA	D	750	3GZF294730-944	3GZF294730-759	3GZF294730-301		2x Ø48-60	4x240
355 SMA	E	370	3GZF294730-753	3GZF294730-753	2x 3GZF294730-613	2x M63x1.5	2x Ø32-49	2x240
355 SMB, SMC		750	3GZF294730-944	3GZF294730-759	3GZF294730-301		2x Ø48-60	4x240
355 ML, LK		750	3GZF294730-944	3GZF294730-759	3GZF294730-501		2x Ø60-80	4x240
400 L, LK		750	3GZF294730-944	3GZF294730-759	3GZF294730-501		2x Ø60-80	4x240

1500 r/min (4 poles)

280		210	3GZF294730-749	3GZF294730-749	2x 3GZF294730-613	2x M63x1.5	2x Ø32-49	2x150
315SM, ML		370	3GZF294730-753	3GZF294730-753	2x 3GZF294730-613	2x M63x1.5	2x Ø32-49	2x240
315LKA, LKB		370	3GZF294730-753	3GZF294730-753	2x 3GZF294730-613	2x M63x1.5	2x Ø32-49	2x240
315LKC		750	3GZF294730-944	3GZF294730-759	3GZF294730-301		2x Ø48-60	4x240
355 SMA	D	750	3GZF294730-944	3GZF294730-759	3GZF294730-301		2x Ø48-60	4x240
355 SMA	E	370	3GZF294730-753	3GZF294730-753	2x 3GZF294730-613	2x M63x1.5	2x Ø32-49	2x240
355 SMB, SMC		750	3GZF294730-944	3GZF294730-759	3GZF294730-301		2x Ø48-60	4x240
355 ML, LK		750	3GZF294730-944	3GZF294730-759	3GZF294730-501		2x Ø60-80	4x240
400 L, LK		750	3GZF294730-944	3GZF294730-759	3GZF294730-501		2x Ø60-80	4x240

1000 r/min (6 poles)

280		210	3GZF294730-749	3GZF294730-749	2x 3GZF294730-613	2x M63x1.5	2x Ø32-49	2x150
315		370	3GZF294730-753	3GZF294730-753	2x 3GZF294730-613	2x M63x1.5	2x Ø32-49	2x240
355 SMA, SMB		370	3GZF294730-753	3GZF294730-753	2x 3GZF294730-613	2x M63x1.5	2x Ø32-49	2x240
355 SMC	D	750	3GZF294730-944	3GZF294730-759	3GZF294730-301		2x Ø48-60	4x240
355 SMC	E	370	3GZF294730-753	3GZF294730-753	2x 3GZF294730-613	2x M63x1.5	2x Ø32-49	2x240
355 ML		750	3GZF294730-944	3GZF294730-759	3GZF294730-301		2x Ø48-60	4x240
355 LKA		750	3GZF294730-944	3GZF294730-759	3GZF294730-301		2x Ø48-60	4x240
355 LKB		750	3GZF294730-944	3GZF294730-759	3GZF294730-501		2x Ø60-80	4x240
400 L, LK		750	3GZF294730-944	3GZF294730-759	3GZF294730-501		2x Ø60-80	4x240

750 r/min (8 poles)

280		210	3GZF294730-749	3GZF294730-749	2x 3GZF294730-613	2x M63x1.5	2x Ø32-49	2x150
315		370	3GZF294730-753	3GZF294730-753	2x 3GZF294730-613	2x M63x1.5	2x Ø32-49	2x240
355 SM		370	3GZF294730-753	3GZF294730-753	2x 3GZF294730-613	2x M63x1.5	2x Ø32-49	2x240
355 ML	D	750	3GZF294730-944	3GZF294730-759	3GZF294730-301		2x Ø48-60	4x240
355 ML	E	370	3GZF294730-753	3GZF294730-753	2x 3GZF294730-613	2x M63x1.5	2x Ø32-49	2x240
355 LK		750	3GZF294730-944	3GZF294730-759	3GZF294730-301		2x Ø48-60	4x240
400 LA, LB, LKA, LKB		750	3GZF294730-944	3GZF294730-759	3GZF294730-301		2x Ø48-60	4x240
400 LC, LKC		750	3GZF294730-944	3GZF294730-759	3GZF294730-501		2x Ø60-80	4x240

Voltage/frequency codes:

D = 380-420 VD 50 Hz, 660/690 VY 50 Hz, 440-480 VD 60 Hz

E = 500 VD 50 Hz, 575 VD 60 Hz

Terminal bolt sizes M12.

Terminal box	Cable cross-section	Max. rated current	
		D-connection	Y-connection
210	25 mm ²	260	150
210	35 mm ²	363	210
370	50 mm ²	470	270
370	70 mm ²	640	370
750	2 x 70 mm ²	950	550
750	2 x 95 mm ²	1300	750

Cable cross-section area between the winding and the terminal board.

M3BP 280 - 315

M3BP 355 - 400

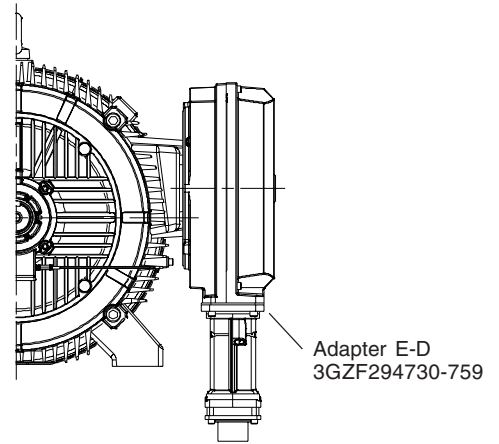
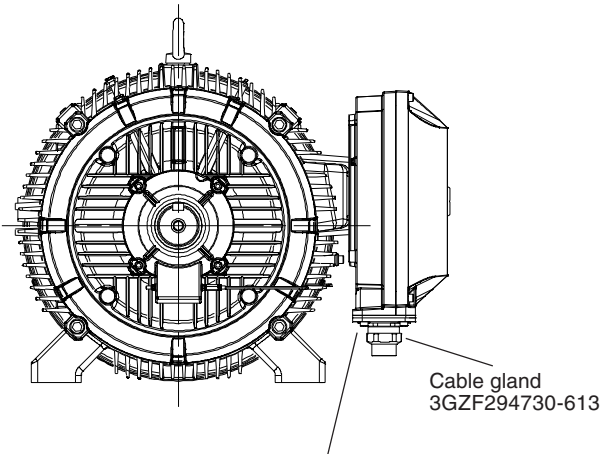

Flange
3GZF294730-749 (M3BP 280)
3GZF294730-753 (M3BP 315)

Adapter D-D (optional)
3GZF294730-942

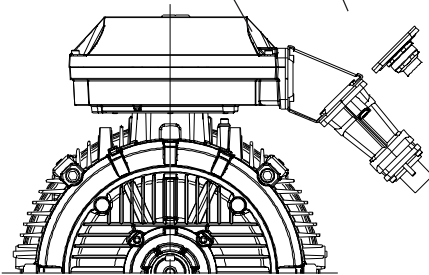

Adapter E-2D (optional)
3GZF294730-945

Adapter E-D (standard)
3GZF294730-944

Cable box
3GZF294730-301

Cable box
3GZF294730-501

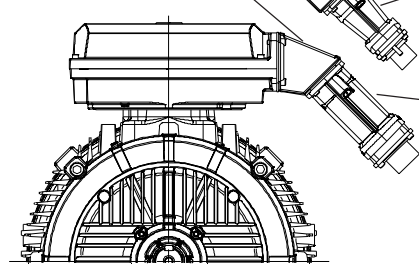

Auxiliary devices (view from N-end)

Cable glands for auxiliary devices
as standard 2 x M20 x 1.5.

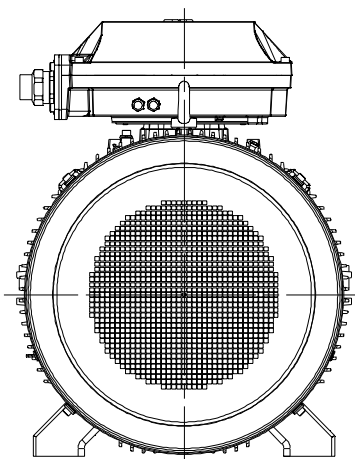

Dimensions for terminal box inlets

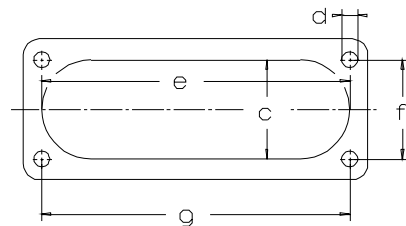

Inlet	c	e	f	g	d
C	62	193	62	193	M8
D	100	300	80	292	M10
E	115	370	100	360	M12

Bearings

The motors are normally fitted with single-row deep groove ball bearings as listed in the table below.

If the bearing at the D-end is replaced with a roller bearing (NU- or NJ-), higher radial forces can be handled. Roller bearings are suitable for belt drive applications.

Basic version with deep groove ball bearings

Motor size	Number of poles	Deep groove ball bearings	
		D-end	N-end
71	2-6	6202 2RS C3	6202 2RS C3
80	2-6	6204 2RS C3	6204 2RS C3
90	2-6	6205 2RS C3	6205 2RS C3
100	2-6	6206 2RS C3	6206 2RS C3
112	2-6	6207 2RS C3	6206 2RS C3
132	2-6	6208 2RS C3	6207 2RS C3
160	2-12	6309/C3	6309/C3
180	2-12	6310/C3	6309/C3
200	2-12	6312/C3	6310/C3
225	2-12	6313/C3	6312/C3
250	2-12	6315/C3	6313/C3
280	2	6316/C3	6316/C3
	4-12	6316/C3	6316/C3
315	2	6316/C3	6316/C3
	4-12	6319/C3	6316/C3
355	2	6316M/C3	6316M/C3
	4-12	6322/C3	6316/C3
400	2	6317M/C3	6317M/C3
	4-12	6324/C3	6319/C3

¹⁾ On request

When there are high axial forces, angular-contact ball bearings should be used. This option is available on request. When a motor with angular-contact ball bearings is ordered, the method of mounting and direction and magnitude of the axial force must be specified. For special bearings, please see the variant codes.

Version with roller bearings, variant code 037

Motor size	Number of poles	Roller bearings, variant code 037 D-end
71	2-6	–
80	2-6	–
90	2-6	–
100	2-6	–
112	2-6	–
132	2-6	–
160	2-12	NU 309 ¹⁾
180	2-12	NU 310 ¹⁾
200	2-12	NU 312 ¹⁾
225	2-12	NU 313 ¹⁾
250	2-12	NU 315 ¹⁾
280	2	¹⁾
	4-12	NU 316/C3
315	2	¹⁾
	4-12	NU 319/C3
355	2	¹⁾
400	4-12	NU 322/C3
	2	¹⁾
400	4-12	NU 324/C3

Axially-locked bearings

The outer bearing ring at the D-end can be axially locked with an inner bearing cover. The inner ring is locked by tight tolerance to the shaft.

All motors are equipped as standard with an axially-locked bearing at the D-end.

Transport locking

Motors that have roller bearings or an angular contact ball bearing are fitted with a transport lock before despatch to prevent damage to the bearings during transport. In case of transport locked bearing, motor sizes 280 to 400 are provided with a warning sign.

Locking may also be fitted in other cases where transport conditions are suspected of being potentially damaging.

Bearing seals

Motor sizes 71 to 132 are equipped with sealed bearings (2RS). The size and type of seals for sizes 160 to 400 are in accordance with the table below:

Motor size	Number of poles	Standard design Axial seal		Alternative design Radial seal (DIN 3760)
		D-end	N-end	Variant code 072
160	2-12	RB45	V-45A	45x62x8
180	2-12	RB50	RB45	50x68x8
200	2-12	RB60	V-50A	60x80x8
225	2-12	RB65	V-60A	65x85x10
250	2-12	RB75	V-65A	75x95x10

Axial seal:
RB45...75 = Gamma-ring
V50...95 = V-ring

Motor size	Number of poles	Standard design		Alternative design	
		D-end	N-end	D-end	N-end
280	2	Labyrinth seal	Axial seal VS80	-	Labyrinth seal
280	4-12	Axial seal VS80	Axial seal VS80	Labyrinth seal Radial seal 80x110x10	Labyrinth seal Radial seal 80x110x10
315	2	Labyrinth seal	Axial seal VS80	-	Labyrinth seal
315	4-12	Axial seal VS95	Axial seal VS80	Labyrinth seal Radial seal 95x125x10	Labyrinth seal Radial seal 80x110x10
355	2	Labyrinth seal	Axial seal VS80	-	Labyrinth seal
355	4-12	Labyrinth seal	Axial seal VS80	-	Labyrinth seal
400	2	Labyrinth seal	Labyrinth seal	-	-
400	4-12	Labyrinth seal	Axial seal VS95	-	Labyrinth seal

Motor sizes 71-132

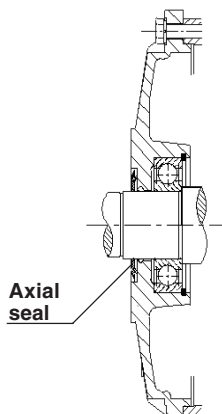

Motor sizes 160-250

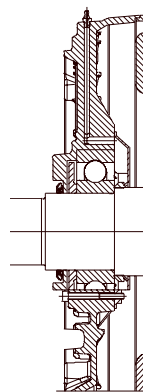

Motor sizes 280-400

Labyrinth seal

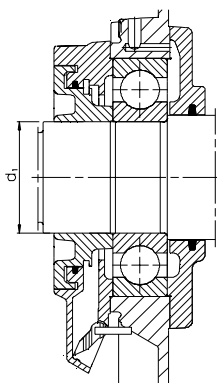

V-ring

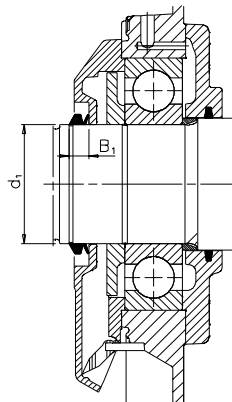

Radial seal

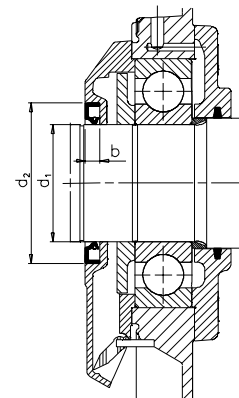

Bearing life

The nominal life L_{10h} of a bearing is defined according to ISO 281 as the number of operating hours achieved or exceeded by 90% of identical bearings in a large test series under certain specified conditions. 50% of the bearings achieve at least five times this figure.

The calculated bearing life L_{10h} for power transmission by means of a coupling (horizontal machine):

Motor sizes 280 to 400 $\geq 200,000$ hours.

Lubrication

On delivery, the motors are ready lubricated with high quality grease. The recommended grease used can be seen from ABB's Low Voltage Motors Manual delivered together with the motor or for frame sizes 280-400 from the lubrication plate fastened to the motor frame. See example of a lubrication plate on page 24.

Motors with permanently greased bearings

Standard versions of frame sizes 71-132 are equipped with closed bearings, type 2RS1. Also motors with frame sizes 160-250 can be equipped with permanently greased bearings. Bearings are lubricated with high quality, high temperature grease. Bearing types are mentioned in the rating plates.

The following values can be used as a guide for bearing lifetime, depending on application and load conditions:

- 4-8 pole motors about 40,000 h
- 2 pole motors about 20,000 h

Lubrication intervals

ABB follows the L1-principle in defining lubrication interval. That means that 99% of the motors are sure to make the interval time. The lubrication intervals can also be calculated according to the L10-principle, which are normally doubled compared to L1-values. Values available from ABB at request.

Lubrication method in cast iron motors

- M2BA 71-132 Permanent greased bearings as standard
- M3BP 160-400 Regreasable bearings as standard solution
- M3BP 160-250 Permanent greased bearings as an option

Motors with relubrication nipples

For sizes 280 to 400 the bearing system has been built so that a valve disc can be used to ease the lubrication. Motors are lubricated while running.

Grease outlet opening has closing valves at both ends. This should be opened before greasing and closed 1-2 hours after regreasing. After lubrication close the valves. This ensures that the construction is tight and dust or dirt cannot get inside the bearing.

As an option, a grease collection method can be used.

The table below gives lubrication intervals according to the L1-principle for different speeds. The values are valid for horizontal mounted motors (B3), with about 80°C bearing temperature and using high quality grease with lithium complex soap and mineral or PAO-oil.

For more information, see ABB's Low Voltage Motors Manual.

Frame size	Amount of grease g	3600 r/min	3000 r/min	1800 r/min	1500 r/min	1000 r/min	500-750 r/min
------------	--------------------	------------	------------	------------	------------	------------	---------------

Ball bearings: lubrication intervals in duty hours							
112	10	10000	13000	18000	21000	25000	28000
132	15	9000	11000	17000	19000	23000	26500
160	25	7000	9500	14000	17000	21000	24000
180	30	6000	8000	13500	16000	20000	23000
200	40	4000	6000	11000	13000	17000	21000
225	50	3000	5000	10000	12500	16500	20000
250	60	2500	4000	9000	11500	15000	18000
280	35	2000	3500	-	-	-	-
280	70	-	-	8000	10500	14000	17000
315	35	2000	3500	-	-	-	-
315	90	-	-	6500	8500	12500	16000
355	35	1200	2000	-	-	-	-
355	120	-	-	4200	6000	10000	13000
400	40	1000	1600	-	-	-	-
400	130	-	-	2800	4600	8400	12000

Frame size	Amount of grease g	3600 r/min	3000 r/min	1800 r/min	1500 r/min	1000 r/min	500-750 r/min
------------	--------------------	------------	------------	------------	------------	------------	---------------

Roller bearings: lubrication intervals in duty hours							
160	25	3500	4500	7000	8500	10500	12000
180	30	3000	4000	7000	8000	10000	11500
200	40	2000	3000	5500	6500	8500	10500
225	50	1500	2500	5000	6000	8000	10000
250	60	1300	2200	4500	5700	7500	9000
280	35	1000	1800	-	-	-	-
280	70	-	-	4000	5300	7000	8500
315	35	1000	1800	-	-	-	-
315	90	-	-	3300	4300	6000	8000
355	35	600	1000	-	-	-	-
355	120	-	-	2000	3000	5000	6500
400	40	500	800	-	-	-	-
400	130	-	-	1400	2300	4200	6000

Pulley diameter

When the desired bearing life has been determined, the minimum permissible pulley diameter can be calculated using F_R , as follows:

$$D = \frac{1.9 \cdot 10^7 \cdot K \cdot P}{n \cdot F_R}$$

where:

D = diameter of pulley, mm

P = power requirement, kW

n = motor speed, r/min

K = belt tension factor, dependent on belt type and type of duty. A common value for V-belts is 2.5.

F_R = permissible radial force

Permissible loadings on shaft

The tables give the permissible radial force in Newtons, assuming zero axial force. The values are based on normal conditions at 50 Hz and calculated bearing lives for motor sizes 71 to 132 of 20000 hours and for motor sizes 160 to 400 of 20,000 and 40,000 hours.

Motors are foot-mounted IM B3 version with force directed sideways. In some cases the strength of the shaft affects the permissible forces.

At 60 Hz the values must be reduced by 10%. For two-speed motors, the values must be based on the higher speed.

Permissible loads of simultaneous radial and axial forces will be supplied on request.

If the radial force is applied between points X_0 and X_{max} , the permissible force F_R can be calculated from the following formula:

$$F_R = F_{X_0} - \frac{X}{E} (F_{X_0} - F_{X_{max}})$$

E = length of shaft extension in basic version

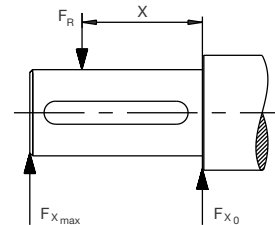

2

Permissible radial forces

Motor sizes 71 to 132

Motor size	Poles	Length of shaft extension E (mm)	Radial forces Ball bearings 20,000 hours		40,000	
			F_{X_0} (N)	$F_{X_{max}}$ (N)	F_{X_0} (N)	$F_{X_{max}}$ (N)
71	2	30	381	322	303	256
	4	30	480	405	381	322
	6	30	555	469	441	372
80 M_ AT	2	40	624	509	495	404
	4	40	788	643	626	51
	6	40	907	740	720	587
80 M_ BT	2	40	624	509	495	404
	4	40	788	643	626	51
	6	40	907	740	720	587
90 S	2	40	686	542	545	430
	4	40	870	687	690	545
	6	40	1000	790	794	627
90 L	2	50	696	564	553	448
	4	50	885	717	702	569
	6	50	1015	823	806	653
100	2	60	979	785	777	622
	4	60	1234	989	979	785
	6	60	1419	1137	1126	903
112	2	60	1258	1014	998	805
	4	60	1592	1284	1264	1019
	6	60	1831	1477	1453	1172
132 S	2	80	1435	1122	1139	890
	4	80	1821	1423	1445	1130
	6	80	2079	1625	1650	1290
132 M	4	80	1840	1476	1461	1172
	6	80	2107	1690	1672	1341

Permissible radial forces

Motor sizes 160 to 400

Motor size	Poles	Length of shaft extension E (mm)	Ball bearings				Roller bearings			
			20,000 hours		40,000 hours		20,000 hours		40,000 hours	
			F _{x0} (N)	F _{xmax} (N)	F _{x0} (N)	F _{xmax} (N)	F _{x0} (N)	F _{xmax} (N)	F _{x0} (N)	F _{xmax} (N)
160	2	110	2980	2310	2350	1810	5530	4260	4370	3360
	4	110	3760	2900	2970	2290	6980	5380	5520	4250
	6	110	4290	3300	3390	2750	7980	6150	6310	4860
	8	110	4730	3660	3740	2880	8800	6780	6960	5360
180	2	110	3540	2880	2790	2260	6260	5080	4940	4010
	4	110	4390	3560	3440	2790	7830	6350	6160	5000
	6	110	5060	4110	3970	3220	9000	7300	7100	5750
	8	110	5590	4540	4390	3560	9940	8060	7830	6350
200 ML_	2	110	4510	3700	3530	2900	8520	7000	6710	5510
	4	110	5660	4650	4430	3640	10710	8800	8440	6930
	6	110	6470	5310	5050	4150	12250	10060	9640	7920
	8	110	7160	5880	5600	5880	13520	11100	10650	8750
225 SM_	2	110	4750	4010	3710	3130	9720	8200	7650	6450
	4	140	6310	5040	4920	3840	12900	10310	10150	8120
	6	140	7200	5760	5620	4500	14740	11800	11600	9280
	8	140	7970	6375	6230	4980	16270	13010	12820	10250
250 SM_	2	140	6100	4910	4750	3830	13600	10960	10710	8640
	4	140	7650	6170	5960	5450	17100	13800	13470	10870
	6	140	8700	7010	6760	5450	19520	15740	15360	12400
	8	140	9630	7760	7505	6050	21550	17380	16970	13690
280 SM_	2	140	7300	6000	5800	4900	20400	6000	16500	6000
	4	140	9200	7800	7300	6200	25100	9200	20300	9200
	6	140	10600	8900	8400	7000	28300	9200	23000	9200
	8	140	11700	9200	9200	7800	30900	9200	25100	9200
315 SM_	2	140	7300	6000	5800	4950	20300	6000	16500	6000
	4	170	11400	9400	9000	7450	32500	9600	26600	9600
	6	170	13000	9600	10300	8500	37000	9600	30000	9600
	8	170	14400	9600	11400	9400	40300	9600	32700	9600
315 ML_	2	140	7400	6400	5850	5050	20600	5850	16700	5850
	4	170	11500	9700	9100	7650	32700	13600	26500	13600
	6	170	13200	11100	10400	8800	36900	13600	29900	13600
	8	170	14500	12200	11500	9700	40200	13600	32600	13600
315 LK_	2	140	7400	6550	5800	5150	20800	5550	16800	5550
	4	170	11500	10000	9100	7850	33100	13350	26800	13350
	6	170	13200	11400	10450	9050	37300	13350	30300	13350
	8	170	14600	12600	11550	10000	40800	13350	33100	13350
355 SM_	2	140	7350	6450	5750	5050	20600	7200	16700	7200
	4	210	15200	12600	12000	9950	45500	14000	36900	14000
	6	210	17500	14000	13800	11400	51400	14000	41700	14000
	8	210	19300	14000	15250	12600	56000	14000	45500	14000
355 ML_	2	140	7350	6550	5750	5100	20800	6750	16800	6750
	4	210	15300	12900	12000	10100	45900	13600	37200	13600
	6	210	17600	13600	13900	11600	51500	13600	42100	13600
	8	210	19400	13600	15300	12900	56000	13600	45900	13600
355 LK_	2	140	7350	6650	5650	5150	21000	6750	17000	6750
	4	210	15200	13000	11850	10200	46000	13000	37300	13000
	6	210	17500	13000	13700	11900	52000	13000	42000	13000
	8	210	19400	13000	15200	13000	56500	13000	46000	13000
400 L_	2	170	7650	6850	4400	3900	23900	9050	19350	9050
	4	210	15600	13550	12150	10550	52500	16000	43300	16000
	6	210	17800	15450	13850	12000	60000	16000	48800	16000
	8	210	19700	16000	15350	13350	65700	16000	53200	16000
400 LK_	2	170	7650	6850	4400	3900	23900	9050	19350	9050
	4	210	15600	11500	12150	10550	52500	11500	43300	11500
	6	210	17800	11500	13850	11500	60000	11500	48800	11500
	8	210	19700	11500	15350	11500	65700	11500	53200	11500

Permissible axial forces

The following tables give the permissible axial forces in Newton, assuming zero radial force. The values are based on normal conditions at 50 Hz with standard bearings and calculated bearing lives of 20,000 and 40,000 hours.

For two-speed motors, the values are to be based on the higher speed. The permissible loads of simultaneous radial and axial forces will be supplied on request.

Given axial forces F_{AD} , assumes D-bearing locked by means of locking ring.

At 60 Hz the values are to be reduced by 10%.

Mounting arrangement IM B3

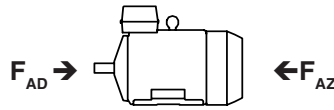

Motor size	20,000 hours								40,000 hours							
	2-pole		4-pole		6-pole		8-pole		2-pole		4-pole		6-pole		8-pole	
	F_{AD} N	F_{AZ} N	F_{AD} N	F_{AZ} N	F_{AD} N	F_{AZ} N	F_{AD} N	F_{AZ} N	F_{AD} N	F_{AZ} N	F_{AD} N	F_{AZ} N	F_{AD} N	F_{AZ} N	F_{AD} N	F_{AZ} N
71	270	270	350	350	440	440	-	-	1)	1)	1)	1)	1)	1)	-	-
80	400	400	510	510	590	590	-	-	1)	1)	1)	1)	1)	1)	-	-
90	450	450	560	560	640	640	-	-	1)	1)	1)	1)	1)	1)	-	-
100	620	620	780	780	890	890	-	-	1)	1)	1)	1)	1)	1)	-	-
112	810	810	1020	1020	1170	1170	-	-	1)	1)	1)	1)	1)	1)	-	-
132 S_	980	980	1220	1220	1400	1400	-	-	1)	1)	1)	1)	1)	1)	-	-
132 M_	980	980	1210	1210	1400	1400	-	-	1)	1)	1)	1)	1)	1)	-	-
160	5240	5240	5230	5230	5220	5220	5240	5240	4650	4650	4630	4630	4630	4630	4740	4740
180	4660	4660	4950	4950	5200	5200	5370	5370	4250	4250	4500	4500	4710	4710	4850	4850
200	3050	3050	3850	3850	4400	4400	4850	4850	2430	2430	3050	3050	3500	3500	3850	3850
225	3440	3440	4340	4340	4960	4960	5460	5460	2730	2730	3440	3440	3940	3940	4340	4340
250	4180	4180	5260	5260	6020	6020	6630	6630	3320	3320	4180	4180	4780	4780	5260	5260
280 SM_	6200	4250	8000	6000	7250	9250	10300	8300	4900	2900	6250	4250	7150	5150	7950	5950
315 SM_	6180	4200	9400	7400	10900	8900	12000	10000	4850	2850	7250	5250	8350	6350	9200	7000
315 ML_	6050	4050	9250	7250	10650	8650	11500	9900	4750	2750	7100	5100	8100	6100	8900	6800
315 LK_	6000	3950	9100	7150	10500	8500	11750	9750	4650	2650	7000	5000	7950	5950	8900	6900
355 SM_	3050	6850	8600	12400	10550	14350	12200	16000	1750	5550	5900	9700	7300	11100	8550	12350
355 ML_	2900	6700	8360	12150	10100	13900	12000	15800	1600	5400	5650	9450	6900	10700	7300	11000
355 LK_	2850	6650	8200	12000	9900	13700	11450	15250	1550	5350	5450	9250	6700	10500	7800	11600
400 L, LK_	2150	7150	7100	13100	8850	14850	10450	16450	1)	5800	4300	10300	5500	11500	6750	12750

1) On request

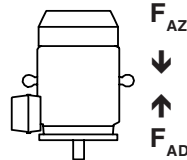

Mounting arrangement IM V1

Motor size	20,000 hours								40,000 hours							
	2-pole		4-pole		6-pole		8-pole		2-pole		4-pole		6-pole		8-pole	
	F_{AD} N	F_{AZ} N	F_{AD} N	F_{AZ} N	F_{AD} N	F_{AZ} N	F_{AD} N	F_{AZ} N	F_{AD} N	F_{AZ} N	F_{AD} N	F_{AZ} N	F_{AD} N	F_{AZ} N	F_{AD} N	F_{AZ} N
71	290	260	380	330	460	420	-	-	1)	1)	1)	1)	1)	1)	-	-
80	430	390	540	490	620	560	-	-	1)	1)	1)	1)	1)	1)	-	-
90	480	420	610	520	700	600	-	-	1)	1)	1)	1)	1)	1)	-	-
100	680	580	880	740	990	840	-	-	1)	1)	1)	1)	1)	1)	-	-
112	890	760	1140	950	1280	1100	-	-	1)	1)	1)	1)	1)	1)	-	-
132 S_	1100	910	1390	1120	1580	1300	-	-	1)	1)	1)	1)	1)	1)	-	-
132 M_	1100	910	1430	1080	1680	1260	-	-	1)	1)	1)	1)	1)	1)	-	-
160	5540	4940	5560	4960	5540	4900	5540	4900	4940	4370	4950	4290	5180	4310	5180	4310
180	5040	4320	5470	4500	5810	4630	5970	4810	4630	3920	4990	4050	5320	4140	5450	4280
200	3600	2500	4580	3120	5280	3530	5720	3980	2970	1870	3780	2320	4370	2620	4720	2980
225	4140	2740	5230	3440	6030	3900	6530	4400	3430	2030	4330	2550	5010	2870	5400	3270
250	5020	3330	6380	4150	7440	4610	8050	5210	4160	2470	5290	3060	6200	3360	6680	3840
280 SM_	7550	3150	9600	4550	11150	5500	12200	7000	6200	1800	7800	2750	9000	3350	9850	4700
315 SM_	7950	2600	11750	5500	13600	6300	15350	7900	6600	1300	9550	3300	11050	3750	12450	5000
315 ML_	8650	2300	12500	5050	14900	5800	15400	6300	7300	1)	10300	2900	12350	3250	13600	3400
315 LK_	9100	1350	13100	3850	15700	4100	16900	6300	7750	1)	10900	1700	13100	1550	14100	3450
355 SM_	6350	4250	13250	8600	15650	9580	17350	12500	4950	2900	10450	5850	12350	6270	13600	8900
355 ML_	7100	3700	14600	7950	18050	8600	21100	11650	5750	2350	11850	5150	14700	5300	17000	7600
355 LK_	7500	3150	15650	6600	19100	7050	21200	8700	6150	1800	12850	3800	15800	3750	17500	5000
400 L, LK_	8650	2150	16050	6400	18450	6750	20100	8350	7220	1)	13150	3400	15100	3400	16450	4700

1) On request



Rating plate

For motor sizes 71 to 132 the rating plate gives one current value for the voltage area. That is the highest current that can occur within the voltage area with the given output.

Motor sizes 71 to 132

ABB		ABB Motors				CE	
3~Mot. M2BA 132M4A		IEC34-1		3GBA132310-ADA			
6208/C3		6207/C3		IP		cl. F	
V	Hz	r/min		cosφ	A		
380-420Δ	50	1440	7.5	0.85	15.2		
660-690Y	50	1440	7.5	0.85	8.78		
440-480Δ	50	1730	8.6	0.86	14.74		
No 3010071152				73		kg	

For motor sizes 160 to 400 the rating plate is in table form giving values for speed, current and power factor for six voltages.

Motor sizes 160 to 250

ABB		Eff1		CE			
3~Motor M3BP 160 MA 2		IEC 160 M/L 42		No 1)			
		Ins.cl. F		IP55			
V	Hz	kW	r/min	A	cosφ	I _A /I _N	t _E /s
690 Y	50	11	2930	11.5	0.88		
400 Δ	50	11	2930	20	0.88		
660 Y	50	11	2915	11.8	0.89		
380 Δ	50	11	2915	20.5	0.89		
415 Δ	50	11	2935	19.4	0.86		
440 Δ	60	14.5	3485	24	0.9		
Prod.code 3GBP 161 101-ADA							
6309/C3		6309/C3		105 Kg			
3GVZ 193 009-1		IEC 60034-1					

Motor sizes 280 to 400 Rating plate

ABB Oy, Electrical Machines LV Motors, Vaasa, Finland		CE					
3~Motor M3BP 315 SMB 4 B3		IEC 315 S/M 80		No. 3291111 7711 SM			
S1		Ins.cl. F		IP 55		Duty	
V	Hz	kW	r/min	A	cosφ		
690 Y	50	160	1487	166	0.85		
400 D	50	160	1487	287	0.85		
660 Y	50	160	1485	171	0.86		
380 D	50	160	1485	296	0.86		
415 D	50	160	1488	279	0.84		
440 D	60	185	1785	295	0.86		
Prod.code 3GBP312230-ADG							
		Nmax 2300 r/min					
6319/C3		6316/C3		1000 kg			
		IEC 60034-1					

Motor sizes 280 to 400 Lubrication plate

ABB							
Regreasing intervals in duty hours							
Bearings		6319		6316			
Amount of grease		90g		70g			
Mounting	Ambient temp.	1800 r/min	1500 r/min	1000 r/min	500-900 r/min		
Hor	25°C	6500	8500	12500	16000		
Hor	40°C	3250	4250	6250	8000		
Vert	25°C	3250	4250	6250	8000		
Vert	40°C	1630	2130	3130	4000		
Do not exceed the motor max. speed							
The following or similar high performance grease can be used:							
Esso	Unirex N2, N3 or S2	Mobil	Mobilith SHC 100				
Shell	Albida EMS2	Klüber	Klüberplex BEM 41-132				
SKF	LGHQ 3	FAG	Arcanol TEMP110				
See the "Low Voltage Motors Manual"							

Ordering information

Sample order

When placing an order, please state the following minimum data in the order, as in example.

The product code of the motor is composed in accordance with the following example.

Motor type	M3BP 160L
Pole number	2
Mounting arrangement (IM code)	IM B3 (IM 1001)
Rated output	18.5 kW
Product code	3GBP161103-ADA
Variant codes if needed	

Motor size

A	B	C	D, E, F, G													
M3BP	160 L	3GBP 161 103	- A D A 003 etc.													
			1	2	3	4	5	6	7	8	9	10	11	12	13	14

- A** Motor type
- B** Motor size
- C** Product code
- D** Mounting arrangement code
- E** Voltage and frequency code
- F** Generation code
- G** Variant codes

Explanation of the product code:

Positions 1 to 4

3GBA/3GBP = Totally enclosed fan cooled squirrel cage motor with cast iron frame

Positions 5 and 6

IEC-frame

07 = 71	20 = 200
08 = 80	22 = 225
09 = 90	25 = 250
10 = 100	28 = 280
11 = 112	31 = 315
13 = 132	35 = 355
16 = 160	40 = 400
18 = 180	

Position 7

Speed (Pole pairs)

- 1** = 2 poles
- 2** = 4 poles
- 3** = 6 poles
- 4** = 8 poles
- 5** = 10 poles
- 6** = 12 poles
- 7** = >12 poles
- 8** = Two-speed motors for fan drive
- 9** = Multi-speed motors, two-speed motors for constant torque

Position 8 to 10

Serial number

Position 11

- (dash)

Position 12

Mounting arrangement

- A** = Foot-mounted, top-mounted terminal box
- R** = Foot-mounted, terminal box RHS seen from D-end
- L** = Foot-mounted, terminal box LHS seen from D-end
- B** = Flange-mounted, large flange
- C** = Flange-mounted, small flange (sizes 71 to 112)
- H** = Foot- and flange-mounted, terminal box top-mounted
- J** = Foot- and flange-mounted, small flange with tapped holes
- S** = Foot- and flange-mounted, terminal box RHS seen from D-end
- T** = Foot- and flange-mounted, terminal box LHS seen from D-end
- V** = Flange-mounted, special flange
- F** = Foot- and flange-mounted. Special flange

Position 13

Voltage and frequency code

See table below

Position 14

Generation code

A, B, C...

The product code must be, if needed, followed by variant codes.

Code letters for supplementing the product code - single speed motors

Code letter for voltage and frequency

Direct start or, with Δ-connection, also Y/Δ-start

Motor size	S		D		H	E		F	T	U	X
	50Hz	60 Hz	50 Hz	60 Hz		50 Hz	60 Hz				
71-132	220-240 VΔ	440-480 VY	380-420 VΔ	440-480VΔ	415 VΔ	500 VΔ	575 VΔ	500 VY	660 VΔ	690 VΔ	Other rated voltage, connection or frequency, 690 V maximum
	380-420 VY	-	660-690 VY	-	-	-	-	-	-	-	
160-400	220, 230 VΔ	-	380, 400, 415 VΔ	440VΔ	415 VΔ	500 VΔ	-	500 VY	660 VΔ	690 VΔ	Other rated voltage, connection or frequency, 690 V maximum
	380,400,415VY	440VY	660, 690 VY	-	-	-	-	-	-	-	

Code letters for supplementing the product code - two speed motors

Code letter for voltage (50 Hz)

Motor size	A	S	B	D	H	E	X
160-400	220 V	230 V	380 V	400 V	415 V	500 V	Other rated voltage, connection or frequency, 690 V maximum



LV Process performance cast iron motors

Technical data for totally enclosed squirrel cage three phase motors



IP 55 – IC 411 – Insulation class F, temperature rise class B

Output kW	Motor type	Product code	Speed r/min	Efficiency		Power factor cos φ 100%	Current		Torque			
				Full load 100%	3/4 load 75%		I _N A	I _s A	T _N Nm	T _s Nm	T _{max} Nm	
3000 r/min = 2 poles			400 V 50 Hz				Basic design					
0.37	M2BA 71 M2 A	3GBA 071 310-••A	2810	71.0	68.1	0.80	0.94	6.1	1.26	2.2	3.0	
0.55	M2BA 71 M2 B	3GBA 071 320-••A	2800	74.0	71.4	0.82	1.31	6.1	1.88	2.2	2.7	
0.75	M2BA 80 M2 A	3GBA 081 310-••A	2850	77.2	75.5	0.86	1.63	6.1	2.51	2.2	3.0	
1.1	³⁾ M2BA 80 M2 B	3GBA 081 320-••A	2850	80.2	77.6	0.85	2.33	7.0	3.69	2.2	2.2	
1.5	³⁾ M2BA 90 S2 A	3GBA 091 110-••A	2850	81.6	79.0	0.85	3.13	7.0	5.03	2.2	2.5	
2.2	³⁾ M2BA 90 L2 A	3GBA 091 510-••A	2850	84.2	81.9	0.84	4.49	7.0	7.37	2.2	3.5	
3	³⁾ M2BA 100 L2 A	3GBA 101 510-••A	2870	85.1	83.2	0.86	5.92	7.0	9.98	2.2	3.0	
4	³⁾ M2BA 112 M2 A	3GBA 111 310-••A	2900	86.0	84.5	0.89	7.52	7.0	13.17	2.2	3.2	
5.5	³⁾ M2BA 132 S2 A	3GBA 131 110-••A	2920	88.6	88.1	0.88	10.19	7.0	17.99	2.2	3.0	
7.5	³⁾ M2BA 132 S2 B	3GBA 131 120-••A	2920	89.9	88.7	0.89	13.54	7.0	24.53	2.2	3.4	
11	M3BP 160 MA	3GBP 161 101-••A	2930	91.2	91.2	0.88	20	6.3	36	1.9	2.5	
15	¹⁾ M3BP 160 M	3GBP 161 102-••A	2920	91.3	91.3	0.90	26.5	6.6	49	2.3	2.5	
18.5	¹⁾ M3BP 160 L	3GBP 161 103-••A	2920	92.4	92.4	0.91	32	7.3	60	2.6	2.7	
22	M3BP 180 M	3GBP 181 101-••A	2930	92.8	92.8	0.89	38.5	7.2	71	2.5	2.7	
30	M3BP 200 MLA	3GBP 201 001-••A	2955	93.2	93.2	0.88	53	7.3	97	2.4	3.1	
37	M3BP 200 MLB	3GBP 201 002-••A	2950	93.6	93.6	0.89	64	7.3	120	2.5	3.2	
45	M3BP 225 SMB	3GBP 221 001-••A	2960	93.9	93.9	0.88	79	7.3	145	2.5	2.8	
55	M3BP 250 SMA	3GBP 251 001-••A	2970	94.4	94.4	0.89	95	7.5	177	2.0	3.0	
75	⁴⁾ M3BP 280 SMA	3GBP 281 210-••G	2978	94.8	94.3	0.88	131	7.6	240	2.1	3.0	
90	⁴⁾ M3BP 280 SMB	3GBP 281 220-••G	2976	95.1	94.8	0.90	152	7.4	289	2.1	2.9	
110	⁴⁾ M3BP 315 SMA	3GBP 311 210-••G	2982	95.1	94.4	0.86	194	7.6	352	2.0	3.0	
132	⁴⁾ M3BP 315 SMB	3GBP 311 220-••G	2982	95.4	94.9	0.88	228	7.4	423	2.2	3.0	
160	⁴⁾ M3BP 315 SMC	3GBP 311 230-••G	2981	96.1	95.6	0.89	269	7.5	513	2.3	3.0	
200	⁴⁾ M3BP 315 MLA	3GBP 311 410-••G	2980	96.3	95.9	0.90	336	7.7	641	2.6	3.0	
250	⁴⁾ M3BP 355 SMA	3GBP 351 210-••G	2984	96.3	95.8	0.89	425	7.7	800	2.1	3.3	
315	⁴⁾ M3BP 355 SMB	3GBP 351 220-••G	2980	96.5	96.2	0.89	535	7.0	1009	2.1	3.0	
355	⁴⁾ M3BP 355 SMC	3GBP 351 230-••G	2984	96.7	96.4	0.88	604	7.2	1136	2.2	3.0	
400	⁴⁾ M3BP 355 MLA	3GBP 351 410-••G	2982	96.8	96.5	0.88	680	7.1	1281	2.3	2.9	
450	⁴⁾ M3BP 355 MLB	3GBP 351 420-••G	2983	97.0	96.8	0.90	750	7.9	1441	2.2	3.6	
500	⁴⁾ M3BP 355 LKA	3GBP 351 810-••G	2982	97.0	96.9	0.90	830	7.5	1601	2.1	3.5	
560	⁴⁾ M3BP 355 LKB	3GBP 351 820-••G	2982	97.1	96.9	0.90	930	8.0	1793	2.3	3.6	
560	⁵⁾ M3BP 400 LA	3GBP 401 510-••G	2988	97.2	97.0	0.89	940	7.8	1790	2.1	3.4	
560	⁵⁽⁶⁾ M3BP 400 LKA	3GBP 401 810-••G	2988	97.2	97.0	0.89	940	7.8	1790	2.1	3.4	
630	⁵⁾ M3BP 400 LB	3GBP 401 520-••G	2987	97.3	97.1	0.89	1055	7.8	2014	2.2	3.4	
630	⁵⁽⁶⁾ M3BP 400 LKB	3GBP 401 820-••G	2987	97.3	97.1	0.89	1055	7.8	2014	2.2	3.4	
710	⁵⁾ M3BP 400 LC	3GBP 401 530-••G	2987	97.4	97.3	0.89	1185	7.8	2270	2.6	3.4	
710	⁵⁽⁶⁾ M3BP 400 LKC	3GBP 401 830-••G	2987	97.4	97.3	0.89	1185	7.8	2270	2.6	3.4	
3000 r/min = 2 poles			400 V 50 Hz				High-output design					
22	¹⁾ M3BP 160 LB	3GBP 161 104-••A	2920	92.1	92.1	0.91	38	7.1	72	2.6	2.6	
30	¹⁾ M3BP 180 LB	3GBP 181 102-••A	2945	93.7	93.7	0.89	53	8.3	97	3.1	3.4	
45	M3BP 200 MLC	3GBP 201 003-••A	2950	93.8	93.8	0.89	78	7.3	146	2.6	3.3	
55	M3BP 225 SMC	3GBP 221 002-••A	2960	94.3	94.3	0.89	95	7.0	177	2.5	2.9	
75	M3BP 250 SMB	3GBP 251 002-••A	2970	94.7	94.7	0.90	127	8.2	241	2.6	3.2	
110	⁴⁾ M3BP 280 SMC	3GBP 281 230-••G	2978	95.7	95.3	0.90	185	7.9	353	2.4	3.0	
250	⁴⁾ M3BP 315 LKA	3GBP 311 810-••G	2980	96.4	96.2	0.89	422	8.1	801	2.8	2.9	
315	¹⁽⁴⁾ M3BP 315 LKC	3GBP 311 830-••G	2981	96.6	96.5	0.89	530	8.8	1009	3.2	3.2	

¹⁾ Temperature rise class F

²⁾ Temperature rise class F at 380 V 50 Hz

³⁾ EU efficiency class eff2; corresponding motor with efficiency class eff1 available on request.

⁴⁾ -3dB(A) sound pressure level reduction with unidirectional fan construction. Direction of rotation must be stated when ordering, see variant codes 044 and 045.

⁵⁾ Unidirectional fan construction as standard. Direction of rotation must be stated when ordering, see variant codes 044 and 045.

⁶⁾ Size with alternative dimensions

The two bullets in the product code indicate choice of mounting arrangement, voltage and frequency (see ordering information page).

LV Process performance cast iron motors

Technical data for totally enclosed squirrel cage three phase motors

IP 55 – IC 411 – Insulation class F, temperature rise class B

Output kW	Motor type	Speed r/min	Efficiency %	Power factor cos φ	Current I _N A	Speed r/min	Efficiency %	Power factor cos φ	Current I _N A	Moment of inertia J = ¼ GD ² kgm ²	Weight kg	Sound pressure level L _p dB(A)
3000 r/min = 2 poles		380 V 50 Hz				415 V 50 Hz				Basic design		
0.37	M2BA 71 M2 A	2795	71.0	0.83	0.96	2825	71.0	0.78	0.93	0.0003	10	56
0.55	M2BA 71 M2 B	2795	74.0	0.83	1.37	2815	74.0	0.79	1.31	0.0004	11	56
0.75	M2BA 80 M2 A	2835	77.0	0.87	1.70	2865	77.2	0.86	1.58	0.0009	16	57
1.1 ³⁾	M2BA 80 M2 B	2835	79.0	0.86	2.46	2865	80.2	0.83	2.30	0.0011	17	58
1.5 ³⁾	M2BA 90 S2 A	2835	81.0	0.89	3.17	2865	81.6	0.84	3.05	0.0014	21	61
2.2 ³⁾	M2BA 90 L2 A	2835	84.0	0.88	4.53	2865	84.0	0.80	4.56	0.0016	24	61
3 ³⁾	M2BA 100 L2 A	2855	85.0	0.88	6.1	2885	85.5	0.84	5.82	0.004	33	65
4 ³⁾	M2BA 112 M2 A	2885	86.2	0.89	7.9	2915	86.2	0.86	7.49	0.0067	42	67
5.5 ³⁾	M2BA 132 S2 A	2905	88.5	0.89	10.7	2935	88.5	0.87	9.94	0.0124	58	70
7.5 ³⁾	M2BA 132 S2 B	2905	88.5	0.89	14.47	2935	90.0	0.89	13.03	0.0149	63	70
11	M3BP 160 MA	2915	90.8	0.89	20.5	2935	91.3	0.86	19.4	0.039	105	69
15 ²⁾	M3BP 160 M	2905	91.0	0.90	27.5	2925	91.7	0.89	25.5	0.047	118	69
18.5 ²⁾	M3BP 160 L	2910	92.0	0.91	33.5	2930	92.6	0.90	31	0.053	133	69
22	M3BP 180 M	2930	92.4	0.90	40.5	2945	93.0	0.88	38	0.077	178	69
30	M3BP 200 MLA	2955	93.1	0.89	55	2960	93.3	0.86	52	0.15	250	72
37	M3BP 200 MLB	2950	93.4	0.89	68	2955	93.7	0.87	63	0.18	270	72
45	M3BP 225 SMB	2955	93.7	0.89	82	2965	93.9	0.87	77	0.26	335	74
55	M3BP 250 SMA	2960	94.3	0.89	100	2970	94.5	0.88	92	0.49	420	75
75 ⁴⁾	M3BP 280 SMA	2975	94.7	0.89	137	2980	94.8	0.87	127	0.8	625	77
90 ⁴⁾	M3BP 280 SMB	2972	95.0	0.90	159	2978	95.1	0.89	148	0.9	665	77
110 ⁴⁾	M3BP 315 SMA	2980	95.1	0.87	202	2983	95.1	0.85	190	1.2	880	78
132 ⁴⁾	M3BP 315 SMB	2980	95.4	0.89	238	2983	95.4	0.87	222	1.4	940	78
160 ⁴⁾	M3BP 315 SMC	2979	96.1	0.90	282	2982	96.1	0.89	262	1.7	1025	78
200 ⁴⁾	M3BP 315 MLA	2977	96.3	0.90	354	2982	96.3	0.89	325	2.1	1190	78
250 ⁴⁾	M3BP 355 SMA	2982	96.2	0.90	445	2985	96.3	0.88	412	3	1600	83
315 ⁴⁾	M3BP 355 SMB	2978	96.4	0.89	560	2982	96.5	0.89	515	3.4	1680	83
355 ⁴⁾	M3BP 355 SMC	2981	96.7	0.89	632	2985	96.7	0.88	582	3.6	1750	83
400 ²⁾⁴⁾	M3BP 355 MLA	2980	96.7	0.89	710	2984	96.8	0.87	660	4.1	2000	83
450 ²⁾⁴⁾	M3BP 355 MLB	2980	96.9	0.91	785	2985	97.0	0.90	720	4.3	2080	83
500 ²⁾⁴⁾	M3BP 355 LKA	2979	96.9	0.91	870	2984	97.0	0.90	800	4.8	2320	83
560 ²⁾⁴⁾	M3BP 355 LKB	2980	97.0	0.91	980	2984	97.1	0.90	895	5.2	2460	83
560 ⁵⁾	M3BP 400 LA	2986	97.2	0.90	980	2989	97.2	0.88	910	7.9	2950	82
560 ⁵⁾⁶⁾	M3BP 400 LKA	2986	97.2	0.90	980	2989	97.2	0.88	910	7.9	2950	82
630 ²⁾⁵⁾	M3BP 400 LB	2985	97.2	0.90	1100	2988	97.3	0.88	1015	8.2	3050	82
630 ²⁾⁵⁾⁶⁾	M3BP 400 LKB	2985	97.2	0.90	1100	2988	97.3	0.88	1015	8.2	3050	82
710 ²⁾⁵⁾	M3BP 400 LC	2985	97.3	0.90	1230	2988	97.5	0.89	1140	9.3	3300	82
710 ²⁾⁵⁾⁶⁾	M3BP 400 LKC	2985	97.3	0.90	1230	2988	97.5	0.89	1140	9.3	3300	82
3000 r/min = 2 poles		380 V 50 Hz				415 V 50 Hz				High-output design		
22 ²⁾	M3BP 160 LB	2910	91.6	0.91	40	2925	92.4	0.90	37	0.058	140	69
30 ²⁾	M3BP 180 LB	2940	93.5	0.90	55	2950	93.8	0.87	52	0.092	194	70
45	M3BP 200 MLC	2945	93.5	0.89	82	2955	93.8	0.88	76	0.19	280	72
55	M3BP 225 SMC	2950	94.2	0.89	100	2965	94.3	0.88	92	0.29	355	74
75	M3BP 250 SMB	2965	94.6	0.90	134	2970	94.7	0.89	123	0.57	465	75
110 ⁴⁾	M3BP 280 SMC	2974	95.6	0.91	194	2980	95.7	0.90	179	1.15	725	77
250 ²⁾⁴⁾	M3BP 315 LKA	2977	96.2	0.89	444	2982	96.4	0.89	408	2.65	1440	78
315 ²⁾⁴⁾	M3BP 315 LKC	2978	96.6	0.90	552	2983	96.7	0.89	508	3.3	1630	78

2

LV Process performance cast iron motors

Technical data for totally enclosed squirrel cage three phase motors



IP 55 – IC 411 – Insulation class F, temperature rise class B

Output kW	Motor type	Product code	Speed r/min	Efficiency		Power factor cos φ 100%	Current		Torque			
				Full load 100%	3/4 load 75%		I _N A	I _s I _N	T _N Nm	T _s T _N	T _{max} T _N	
1500 r/min = 4 poles												
400 V 50 Hz												
Basic design												
0.25	M2BA 71 M4 A	3GBA 072 310-••A	1390	66.3	63.3	0.73	0.75	5.2	1.72	2.1	2.7	
0.37	M2BA 71 M4 B	3GBA 072 320-••A	1380	70.8	69.4	0.75	1.01	5.2	2.56	2.1	2.6	
0.55	M2BA 80 M4 A	3GBA 082 310-••A	1410	75.0	72.4	0.73	1.45	5.2	3.73	2.4	2.7	
0.75	M2BA 80 M4 B	3GBA 082 320-••A	1400	76.3	75.1	0.76	1.87	6.0	5.12	2.4	2.6	
1.1	³⁾ M2BA 90 S4 A	3GBA 092 110-••A	1400	78.5	77.8	0.78	2.6	6.0	7.5	2.3	2.4	
1.5	³⁾ M2BA 90 L4 A	3GBA 092 510-••A	1390	80.5	79.2	0.78	3.45	6.0	10.31	2.3	2.6	
2.2	³⁾ M2BA 100 L4 A	3GBA 102 510-••A	1430	82.5	81.7	0.80	4.82	6.0	14.69	2.3	2.7	
3	³⁾ M2BA 100 L4 B	3GBA 102 520-••A	1420	84.5	82.5	0.82	6.25	6.5	20.18	2.3	2.8	
4	³⁾ M2BA 112 M4 A	3GBA 112 310-••A	1430	86.0	84.7	0.81	8.24	6.5	26.71	2.3	2.8	
5.5	³⁾ M2BA 132 S4 A	3GBA 132 110-••A	1430	87.4	87.1	0.84	10.82	6.5	36.73	2.3	2.9	
7.5	³⁾ M2BA 132 M4 A	3GBA 132 310-••A	1440	89.0	88.7	0.85	14.34	6.5	49.74	2.3	2.7	
11	M3BP 160 M	3GBP 162 101-••A	1465	91.5	92.0	0.83	21	7.9	72	3.4	3.4	
15	M3BP 160 L	3GBP 162 102-••A	1460	91.8	92.5	0.82	29	8.1	98	3.0	3.6	
18.5	M3BP 180 M	3GBP 182 101-••A	1470	92.3	92.3	0.84	35	7.0	120	3.1	2.7	
22	M3BP 180 L	3GBP 182 102-••A	1470	93.1	93.6	0.85	40	8.5	143	3.6	2.9	
30	M3BP 200 MLB	3GBP 202 001-••A	1475	93.4	93.6	0.84	55	8.2	194	4.3	3.2	
37	M3BP 225 SMA	3GBP 222 001-••A	1480	93.6	93.6	0.84	68	6.6	239	2.4	2.5	
45	M3BP 225 SMB	3GBP 222 002-••A	1480	94.2	94.2	0.83	83	6.7	290	2.7	2.6	
55	M3BP 250 SMA	3GBP 252 001-••A	1480	94.6	94.6	0.86	98	7.5	355	2.3	2.8	
75	M3BP 280 SMA	3GBP 282 210-••G	1484	94.9	94.8	0.85	135	6.9	483	2.5	2.8	
90	M3BP 280 SMB	3GBP 282 220-••G	1483	95.2	95.2	0.86	159	7.2	580	2.5	2.7	
110	M3BP 315 SMA	3GBP 312 210-••G	1487	95.6	95.4	0.86	193	7.2	706	2.0	2.5	
132	M3BP 315 SMB	3GBP 312 220-••G	1487	95.8	95.6	0.86	232	7.1	848	2.3	2.7	
160	M3BP 315 SMC	3GBP 312 230-••G	1487	96.0	95.9	0.85	287	7.2	1028	2.4	2.9	
200	M3BP 315 MLA	3GBP 312 410-••G	1486	96.2	96.2	0.86	351	7.2	1285	2.5	2.9	
250	M3BP 355 SMA	3GBP 352 210-••G	1488	96.5	96.3	0.86	438	7.1	1604	2.3	2.7	
315	M3BP 355 SMB	3GBP 352 220-••G	1488	96.7	96.6	0.86	550	7.3	2022	2.3	2.8	
355	M3BP 355 SMC	3GBP 352 230-••G	1487	96.7	96.6	0.86	616	6.8	2280	2.4	2.7	
400	M3BP 355 MLA	3GBP 352 410-••G	1489	96.9	96.7	0.85	700	6.8	2565	2.3	2.6	
450	M3BP 355 MLB	3GBP 352 420-••G	1490	96.9	96.7	0.86	784	6.9	2884	2.3	2.9	
500	M3BP 355 LKA	3GBP 352 810-••G	1490	97.0	96.9	0.86	875	6.8	3204	2.0	3.0	
560	¹⁾ M3BP 355 LKB	3GBP 352 820-••G	1490	96.9	96.9	0.85	990	7.2	3589	2.6	2.7	
560	M3BP 400 LA	3GBP 402 510-••G	1491	97.0	96.8	0.85	980	7.4	3587	2.4	3.0	
560	⁴⁾ M3BP 400 LKA	3GBP 402 810-••G	1491	97.0	96.8	0.85	980	7.4	3587	2.4	3.0	
630	M3BP 400 LB	3GBP 402 520-••G	1491	97.0	96.9	0.87	1085	7.6	4035	2.2	3.1	
630	⁴⁾ M3BP 400 LKB	3GBP 402 820-••G	1491	97.0	96.9	0.87	1085	7.6	4035	2.2	3.1	
710	¹⁾ M3BP 400 LC	3GBP 402 530-••G	1491	97.1	97.0	0.86	1240	7.6	4547	2.4	3.2	
710	¹⁴⁾ M3BP 400 LKC	3GBP 402 830-••G	1491	97.1	97.0	0.86	1240	7.6	4547	2.4	3.2	

1500 r/min = 4 poles												
400 V 50 Hz												
High-output design												
18.5	¹⁾ M3BP 160 LB	3GBP 162 103-••A	1450	90.5	92.0	0.84	36	6.7	122	2.8	2.9	
30	¹⁾ M3BP 180 LB	3GBP 182 103-••A	1465	92.5	92.5	0.84	56	6.9	195	3.2	2.8	
37	¹⁾ M3BP 200 MLB	3GBP 202 002-••A	1475	93.4	93.4	0.84	68	7.8	236	3.6	3.2	
55	¹⁾ M3BP 225 SMC	3GBP 222 003-••A	1480	94.6	94.6	0.84	100	7.3	355	3.1	2.8	
75	¹⁾ M3BP 250 SMB	3GBP 252 002-••A	1480	94.2	94.7	0.86	132	7.2	484	3.4	3.5	
110	M3BP 280 SMC	3GBP 282 230-••G	1485	95.6	95.5	0.86	195	7.6	707	3.0	3.0	
250	M3BP 315 LKA	3GBP 312 810-••G	1487	96.1	96.0	0.86	442	7.4	1605	2.5	2.9	
280	M3BP 315 LKB	3GBP 312 820-••G	1487	96.3	96.2	0.86	494	7.6	1798	2.6	3.0	
315	M3BP 315 LKC	3GBP 312 830-••G	1488	96.4	96.2	0.85	555	7.8	2022	2.6	3.2	

¹⁾ Temperature rise class F.

²⁾ Temperature rise class F at 380 V 50 Hz

³⁾ EU efficiency class eff2; corresponding motor with efficiency class eff1 available on request.

⁴⁾ Size with alternative dimensions

The two bullets in the product code indicate choice of mounting arrangement, voltage and frequency (see ordering information page).

LV Process performance cast iron motors

Technical data for totally enclosed squirrel cage three phase motors

IP 55 – IC 411 – Insulation class F, temperature rise class B

Output kW	Motor type	Speed r/min	Efficiency %	Power factor cos φ	Current I _N A	Speed r/min	Efficiency %	Power factor cos φ	Current I _N A	Moment of inertia J = ¼ GD ² kgm ²	Weight kg	Sound pressure level L _p dB(A)
1500 r/min = 4 poles		380 V 50 Hz				415 V 50 Hz				Basic design		
0.25	M2BA 71 M4 A	1380	66.5	0.76	0.76	1400	65.0	0.71	0.76	0.0005	11	43
0.37	M2BA 71 M4 B	1370	70.5	0.78	1.02	1390	70.5	0.71	1.03	0.0007	11	45
0.55	M2BA 80 M4 A	1400	75.0	0.76	1.47	1420	74.0	0.69	1.5	0.0014	16	46
0.75	M2BA 80 M4 B	1390	76.0	0.78	1.93	1410	75.5	0.73	1.9	0.0017	17	46
1.1 ^③	M2BA 90 S4 A	1390	78.0	0.81	2.65	1410	78.5	0.75	2.61	0.0025	21	52
1.5 ^③	M2BA 90 L4 A	1380	80.0	0.80	3.57	1400	80.5	0.75	3.46	0.0037	26	52
2.2 ^③	M2BA 100 L4 A	1420	81.5	0.83	4.95	1440	82.5	0.77	4.82	0.0068	32	53
3 ^③	M2BA 100 L4 B	1410	84.0	0.84	6.46	1430	84.5	0.80	6.18	0.0086	36	53
4 ^③	M2BA 112 M4 A	1420	85.5	0.83	8.52	1440	86.0	0.78	8.24	0.0131	45	56
5.5 ^③	M2BA 132 S4 A	1420	86.5	0.86	11.24	1440	87.5	0.83	10.6	0.0267	60	59
7.5 ^③	M2BA 132 M4 A	1430	88.4	0.85	15.2	1450	88.7	0.84	14.04	0.0343	73	59
11	M3BP 160 M	1460	91.1	0.84	22	1470	91.6	0.82	20.5	0.091	115	62
15	M3BP 160 L	1455	91.8	0.84	30	1465	91.9	0.81	28	0.102	135	62
18.5	M3BP 180 M	1465	91.7	0.85	36	1470	92.2	0.83	34	0.161	175	62
22	M3BP 180 L	1465	92.7	0.86	42	1475	93.3	0.84	38	0.225	203	63
30	M3BP 200 MLB	1470	93.1	0.85	58	1475	93.5	0.84	54	0.34	275	63
37	M3BP 225 SMA	1475	93.4	0.84	72	1480	93.7	0.81	68	0.37	310	66
45	M3BP 225 SMB	1475	94.0	0.85	86	1480	94.2	0.81	82	0.42	330	66
55	M3BP 250 SMA	1475	94.3	0.86	103	1480	94.7	0.84	96	0.72	420	67
75	M3BP 280 SMA	1482	94.7	0.86	141	1486	94.9	0.84	132	1.25	625	68
90	M3BP 280 SMB	1481	95.0	0.87	166	1485	95.2	0.85	155	1.5	665	68
110	M3BP 315 SMA	1486	95.5	0.87	202	1488	95.6	0.85	191	2.3	900	70
132	M3BP 315 SMB	1486	95.7	0.87	242	1488	95.8	0.85	227	2.6	960	70
160	M3BP 315 SMC	1485	95.9	0.86	296	1488	96.0	0.84	279	2.9	1000	70
200 ^②	M3BP 315 MLA	1484	96.1	0.87	366	1488	96.1	0.85	342	3.5	1160	70
250	M3BP 355 SMA	1487	96.4	0.87	455	1489	96.5	0.85	430	5.9	1610	74
315	M3BP 355 SMB	1487	96.7	0.87	571	1489	96.7	0.85	538	6.9	1780	74
355 ^②	M3BP 355 SMC	1485	96.5	0.87	645	1488	96.7	0.85	608	7.2	1820	78
400 ^②	M3BP 355 MLA	1488	96.8	0.86	740	1490	96.9	0.84	685	8.4	2140	78
450 ^②	M3BP 355 MLB	1488	96.8	0.87	825	1491	96.9	0.84	770	8.4	2140	78
500	M3BP 355 LKA	1489	97.0	0.87	907	1491	97.0	0.85	852	10	2500	78
560 ^②	M3BP 355 LKB	1488	96.9	0.86	1020	1491	97.1	0.84	960	10.6	2600	78
560 ^②	M3BP 400 LA	1490	97.0	0.86	1020	1492	97.0	0.84	970	15	3200	78
560 ^{②④)}	M3BP 400 LKA	1490	97.0	0.86	1020	1492	97.0	0.84	970	15	3200	78
630 ^②	M3BP 400 LB	1490	97.0	0.88	1130	1492	97.0	0.86	1055	16	3300	78
630 ^{②④)}	M3BP 400 LKB	1490	97.0	0.88	1130	1492	97.0	0.86	1055	16	3300	78
710 ^②	M3BP 400 LC	1490	97.0	0.87	1290	1492	97.1	0.84	1215	17	3400	78
710 ^{②④)}	M3BP 400 LKC	1490	97.0	0.87	1290	1492	97.1	0.84	1215	17	3400	78
1500 r/min = 4 poles		380 V 50 Hz				415 V 50 Hz				High-output design		
18.5 ^②	M3BP 160 LB	1440	89.8	0.85	37	1450	90.8	0.83	34	0.102	135	63
30 ^②	M3BP 180 LB	1465	92.2	0.85	58	1470	92.7	0.82	55	0.225	203	63
37 ^②	M3BP 200 MLB	1475	93.3	0.85	71	1475	93.3	0.82	67	0.34	275	63
55 ^②	M3BP 225 SMC	1475	94.5	0.84	105	1480	94.6	0.82	99	0.49	355	66
75 ^②	M3BP 250 SMB	1475	93.9	0.87	139	1480	94.4	0.86	128	0.88	465	67
110	M3BP 280 SMC	1483	95.5	0.87	202	1486	95.7	0.85	189	1.85	725	68
250 ^②	M3BP 315 LKA	1485	96.0	0.87	457	1488	96.2	0.85	428	4.4	1410	78
280 ^②	M3BP 315 LKB	1485	96.0	0.87	515	1488	96.3	0.85	480	5	1520	78
315 ^②	M3BP 315 LKC	1486	96.2	0.86	582	1489	96.4	0.84	547	5.5	1600	78

2

LV Process performance cast iron motors

Technical data for totally enclosed squirrel cage three phase motors

IP 55 – IC 411 – Insulation class F, temperature rise class B

Output kW	Motor type	Product code	Speed r/min	Efficiency		Power factor cos φ 100%	Current		Torque			
				Full load 100%	3/4 load 75%		I _N A	I _s / I _N	T _N Nm	T _s / T _N	T _{max} / T _N	
1000 r/min = 6 poles												
400 V 50 Hz												
Basic design												
0.18	M2BA 71 M6 A	3GBA 073 310-••A	880	57.0	50.4	0.63	0.73	4.0	1.95	1.7	2.4	
0.25	M2BA 71 M6 B	3GBA 073 320-••A	880	61.5	58.3	0.65	0.91	4.0	2.71	1.7	2.5	
0.37	M2BA 80 M6 A	3GBA 083 310-••A	920	68.0	63.2	0.65	1.21	5.0	3.84	1.7	2.0	
0.55	M2BA 80 M6 B	3GBA 083 320-••A	920	70.0	65.1	0.66	1.72	5.0	5.71	1.7	1.8	
0.75	M2BA 90 S6 A	3GBA 093 110-••A	920	74.0	70.2	0.71	2.08	5.0	7.79	2.0	2.3	
1.1	M2BA 90 L6 A	3GBA 093 510-••A	920	75.0	73.1	0.73	2.9	5.0	11.42	2.0	2.6	
1.5	M2BA 100 L6 A	3GBA 103 510-••A	930	79.0	75.5	0.73	3.76	5.5	15.4	2.0	2.4	
2.2	M2BA 112 M6 A	3GBA 113 310-••A	940	83.0	81.1	0.73	5.24	5.5	22.35	2.0	2.3	
3	M2BA 132 S6 A	3GBA 133 110-••A	960	84.5	82.4	0.77	6.67	6.5	29.84	2.0	2.4	
4	M2BA 132 M6 A	3GBA 133 310-••A	960	85.0	84.1	0.76	8.94	6.5	39.79	2.0	2.9	
5.5	M2BA 132 M6 B	3GBA 133 320-••A	950	87.0	85.9	0.78	11.7	6.5	55	2.0	3.0	
7.5	M3BP 160 M	3GBP 163 101-••A	970	89.3	90.4	0.79	15.4	6.6	74	1.9	2.6	
11	M3BP 160 L	3GBP 163 102-••A	970	89.8	89.8	0.78	23	7.1	109	2.2	2.9	
15	M3BP 180 L	3GBP 183 101-••A	970	90.8	90.8	0.78	31	7.0	148	2.1	3.0	
18.5	M3BP 200 MLA	3GBP 203 001-••A	985	91.1	91.1	0.81	36	7.0	179	2.5	2.7	
22	M3BP 200 MLB	3GBP 203 002-••A	980	91.7	91.7	0.81	43	7.2	214	2.5	2.7	
30	M3BP 225 SMB	3GBP 223 001-••A	985	92.8	93.0	0.83	56	7.8	291	3.5	3.0	
37	M3BP 250 SMA	3GBP 253 001-••A	985	93.7	93.7	0.83	69	7.3	359	2.8	2.8	
45	M3BP 280 SMA	3GBP 283 210-••G	990	94.4	94.3	0.84	82	7.0	434	2.5	2.5	
55	M3BP 280 SMB	3GBP 283 220-••G	990	94.6	94.6	0.84	101	7.0	531	2.7	2.6	
75	M3BP 315 SMA	3GBP 313 210-••G	992	95.0	94.7	0.82	141	7.4	722	2.4	2.8	
90	M3BP 315 SMB	3GBP 313 220-••G	992	95.5	95.3	0.84	163	7.5	866	2.4	2.8	
110	M3BP 315 SMC	3GBP 313 230-••G	991	95.6	95.5	0.83	202	7.4	1060	2.5	2.9	
132	M3BP 315 MLA	3GBP 313 410-••G	991	95.8	95.7	0.83	240	7.5	1272	2.7	3.0	
160	M3BP 355 SMA	3GBP 353 210-••G	993	96.0	95.8	0.83	293	7.0	1539	2.0	2.6	
200	M3BP 355 SMB	3GBP 353 220-••G	993	96.1	96.0	0.83	360	7.2	1923	2.2	2.7	
250	M3BP 355 SMC	3GBP 353 230-••G	993	96.4	96.2	0.82	458	7.4	2404	2.6	2.9	
315	M3BP 355 MLB	3GBP 353 420-••G	992	96.3	96.1	0.82	578	7.0	3032	2.5	2.7	
355	M3BP 355 LKA	3GBP 353 810-••G	992	96.4	96.2	0.82	655	7.6	3417	2.7	2.9	
400	¹⁾ M3BP 355 LKB	3GBP 353 820-••G	992	96.3	96.2	0.82	740	7.2	3851	2.6	2.6	
400	M3BP 400 LA	3GBP 403 510-••G	993	96.7	96.6	0.82	730	7.1	3847	2.3	2.7	
400	³⁾ M3BP 400 LKA	3GBP 403 810-••G	993	96.7	96.6	0.82	730	7.1	3847	2.3	2.7	
450	M3BP 400 LB	3GBP 403 520-••G	994	96.9	96.7	0.82	818	7.4	4323	2.4	2.8	
450	³⁾ M3BP 400 LKB	3GBP 403 820-••G	994	96.9	96.7	0.82	818	7.4	4323	2.4	2.8	
500	M3BP 400 LC	3GBP 403 530-••G	993	96.9	96.8	0.83	900	7.2	4808	2.5	2.7	
500	³⁾ M3BP 400 LKC	3GBP 403 830-••G	993	96.9	96.8	0.83	900	7.2	4808	2.5	2.7	
560	M3BP 400 LD	3GBP 403 540-••G	993	96.9	96.8	0.85	985	7.4	5385	2.4	3.0	
560	³⁾ M3BP 400 LKD	3GBP 403 840-••G	993	96.9	96.8	0.85	985	7.4	5385	2.4	3.0	
1000 r/min = 6 poles												
400 V 50 Hz												
High-output design												
14	¹⁾ M3BP 160 LB	3GBP 163 103-••A	960	89.1	89.1	0.77	29.5	7.6	139	2.7	3.1	
18.5	¹⁾ M3BP 180 LB	3GBP 183 102-••A	965	90.6	90.6	0.79	37.5	6.2	183	2.0	2.6	
30	¹⁾ M3BP 200 MLC	3GBP 203 003-••A	980	91.7	91.7	0.81	56	7.5	292	3.3	3.0	
37	M3BP 225 SMC	3GBP 223 002-••A	985	93.2	93.9	0.83	69	7.4	359	3.3	2.8	
45	¹⁾ M3BP 250 SMB	3GBP 253 002-••A	985	94.1	94.1	0.84	83	7.5	436	3.7	3.2	
75	M3BP 280 SMC	3GBP 283 230-••G	990	95.1	95.2	0.84	137	7.3	723	2.8	2.7	
160	M3BP 315 LKA	3GBP 313 810-••G	992	95.7	95.6	0.83	293	7.5	1540	2.6	2.8	
180	M3BP 315 LKB	3GBP 313 820-••G	992	95.8	95.7	0.83	330	7.4	1733	2.6	2.8	
200	M3BP 315 LKC	3GBP 313 830-••G	989	95.7	95.7	0.84	362	6.8	1931	2.5	2.6	

¹⁾ Temperature rise class F.

²⁾ Temperature rise class F at 380 V 50 Hz

³⁾ Size with alternative dimensions dimensions.

The two bullets in the product code indicate choice of mounting arrangement, voltage and frequency (see ordering information page).

LV Process performance cast iron motors

Technical data for totally enclosed squirrel cage three phase motors

IP 55 – IC 411 – Insulation class F, temperature rise class B

Output kW	Motor type	Speed r/min	Efficiency %	Power factor cos φ	Current I _N A	Speed r/min	Efficiency %	Power factor cos φ	Current I _N A	Moment of inertia J = ¼ GD ² kgm ²	Weight kg	Sound pressure level L _p dB(A)
1000 r/min = 6 poles		380 V 50 Hz				415 V 50 Hz				Basic design		
0.18	M2BA 71 M6 A	875	57.5	0.67	0.71	885	54.0	0.61	0.77	0.0006	10	42
0.25	M2BA 71 M6 B	875	61.5	0.65	0.95	885	61.0	0.62	0.92	0.0007	11	42
0.37	M2BA 80 M6 A	915	68.0	0.68	1.22	925	66.7	0.61	1.27	0.0016	17	45
0.55	M2BA 80 M6 B	915	70.0	0.68	1.76	925	71.0	0.62	1.74	0.002	18	45
0.75	M2BA 90 S6 A	915	73.5	0.75	2.08	925	73.5	0.67	2.12	0.0029	21	48
1.1	M2BA 90 L6 A	915	74.0	0.78	2.9	925	75.0	0.75	2.92	0.0038	25	48
1.5	M2BA 100 L6 A	925	78.0	0.78	3.75	935	78.8	0.71	3.73	0.01	32	51
2.2	M2BA 112 M6 A	935	82.0	0.75	5.44	945	83.0	0.72	5.13	0.0156	40	54
3	M2BA 132 S6 A	955	83.5	0.80	6.83	965	84.5	0.75	6.6	0.0312	55	56
4	M2BA 132 M6 A	955	85.0	0.76	9.41	965	85.2	0.74	8.83	0.0407	65	56
5.5	M2BA 132 M6 B	945	86.5	0.79	12.24	955	87.5	0.77	11.36	0.0533	75	56
7.5	M3BP 160 M	960	88.7	0.80	16.1	970	89.6	0.77	15.1	0.089	115	59
11	M3BP 160 L	960	89.4	0.80	23.5	970	90.0	0.76	22.4	0.107	135	59
15	M3BP 180 L	970	90.9	0.79	32	975	91.1	0.74	31	0.217	177	59
18.5	M3BP 200 MLA	980	90.8	0.81	38	985	91.1	0.8	36	0.37	245	63
22	M3BP 200 MLB	980	91.6	0.81	45	985	91.8	0.79	42	0.43	260	63
30	M3BP 225 SMB	985	92.6	0.83	59	985	92.9	0.82	55	0.64	320	63
37	M3BP 250 SMA	985	93.5	0.84	72	990	93.8	0.81	67	1.16	415	63
45	M3BP 280 SMA	989	94.2	0.84	87	991	94.4	0.82	81	1.85	605	66
55	M3BP 280 SMB	988	94.5	0.84	106	991	94.6	0.83	99	2.2	645	66
75	M3BP 315 SMA	991	94.9	0.84	145	993	95.0	0.79	140	3.2	830	70
90	M3BP 315 SMB	991	95.4	0.85	169	993	95.5	0.82	160	4.1	930	70
110	M3BP 315 SMC	990	95.5	0.84	211	992	95.6	0.82	197	4.9	1000	70
132	M3BP 315 MLA	990	95.7	0.84	250	992	95.8	0.82	236	5.8	1150	68
160	M3BP 355 SMA	992	95.9	0.84	305	994	96.0	0.82	285	7.9	1520	75
200	M3BP 355 SMB	992	96.1	0.84	380	994	96.1	0.82	358	9.7	1680	75
250	M3BP 355 SMC	992	96.3	0.83	475	994	96.4	0.81	446	11.3	1820	75
315	M3BP 355 MLB	991	96.2	0.83	605	993	96.3	0.81	563	13.5	2180	75
355	²⁾ M3BP 355 LKA	991	96.3	0.83	675	993	96.4	0.81	637	15.5	2500	75
400	²⁾ M3BP 355 LKB	991	96.2	0.83	773	993	96.4	0.81	720	16.5	2600	75
400	M3BP 400 LA	992	96.7	0.83	760	994	96.7	0.8	720	17	2900	76
400	³⁾ M3BP 400 LKA	992	96.7	0.83	760	994	96.7	0.8	720	17	2900	76
450	²⁾ M3BP 400 LB	993	96.8	0.84	850	994	96.9	0.8	815	20.5	3150	76
450	²⁽³⁾ M3BP 400 LKB	993	96.8	0.84	850	994	96.9	0.8	815	20.5	3150	76
500	²⁾ M3BP 400 LC	992	96.8	0.84	940	994	96.9	0.82	888	22	3300	76
500	²⁽³⁾ M3BP 400 LKC	992	96.8	0.84	940	994	96.9	0.82	888	22	3300	76
560	²⁾ M3BP 400 LD	992	96.8	0.86	1035	994	96.9	0.83	970	24	3400	77
560	²⁽³⁾ M3BP 400 LKD	992	96.8	0.86	1035	994	96.9	0.83	970	24	3400	77
1000 r/min = 6 poles		380 V 50 Hz				415 V 50 Hz				High-output design		
14	²⁾ M3BP 160 LB	955	88.7	0.79	30.5	965	89.2	0.75	29.5	0.127	148	62
18.5	²⁾ M3BP 180 LB	965	90.0	0.81	39	965	90.8	0.78	36.5	0.237	185	59
30	²⁾ M3BP 200 MLC	980	91.5	0.83	57	985	91.9	0.83	52	0.49	275	63
37	M3BP 225 SMC	980	93.0	0.83	72	985	93.2	0.81	68	0.75	345	63
45	²⁾ M3BP 250 SMB	985	93.8	0.84	87	985		0.83	81	1.49	460	63
75	M3BP 280 SMC	988	95.0	0.85	142	991	95.2	0.83	132	2.85	725	66
160	M3BP 315 LKA	991	95.7	0.84	304	992	95.8	0.82	285	7.3	1410	74
180	M3BP 315 LKB	990	95.7	0.84	342	992	95.9	0.82	321	8.3	1520	74
200	M3BP 315 LKC	988	95.7	0.84	380	990	95.9	0.83	353	9.2	1600	74

2

LV Process performance cast iron motors

Technical data for totally enclosed squirrel cage three phase motors

IP 55 – IC 411 – Insulation class F, temperature rise class B

Output kW	Motor type	Product code	Speed r/min	Efficiency		Power factor cos φ 100%	Current		Torque			
				Full load 100%	3/4 load 75%		I _N A	I _s / I _N	T _N Nm	T _s / T _N	T _{max} / T _N	
750 r/min = 8 poles			400 V 50 Hz				Basic design					
4	M3BP 160 MA	3GBP 164 101-••A	715	84.1	84.7	0.69	10	5.2	54	2.1	2.4	
5.5 ¹⁾	M3BP 160 M	3GBP 164 102-••A	710	84.7	85.5	0.70	13.4	5.4	74	2.4	2.6	
7.5 ¹⁾	M3BP 160 L	3GBP 164 103-••A	715	86.3	87.2	0.70	18.1	5.4	100	2.4	2.8	
11	M3BP 180 L	3GBP 184 101-••A	720	88.7	89.2	0.76	23.5	5.9	146	2.4	2.6	
15	M3BP 200 MLA	3GBP 204 001-••A	740	91.1	91.1	0.82	29	7.4	194	1.8	3.0	
18.5	M3BP 225 SMA	3GBP 224 001-••A	730	91.1	91.1	0.79	37	6.2	242	1.9	2.7	
22	M3BP 225 SMB	3GBP 224 002-••A	730	91.5	91.5	0.77	45	6.0	288	1.9	2.7	
30	M3BP 250 SMA	3GBP 254 001-••A	735	92.8	92.8	0.79	59	6.9	390	1.9	2.9	
37	M3BP 280 SMA	3GBP 284 210-••G	741	93.4	93.3	0.78	74	7.3	477	1.7	3.0	
45	M3BP 280 SMB	3GBP 284 220-••G	741	94.0	93.8	0.78	90	7.6	580	1.8	3.1	
55	M3BP 315 SMA	3GBP 314 210-••G	742	94.1	94.0	0.81	104	7.1	708	1.6	2.7	
75	M3BP 315 SMB	3GBP 314 220-••G	741	94.4	94.3	0.82	141	7.1	968	1.7	2.7	
90	M3BP 315 SMC	3GBP 314 230-••G	741	94.8	94.7	0.82	167	7.4	1161	1.8	2.7	
110	M3BP 315 MLA	3GBP 314 410-••G	740	95.0	95.0	0.83	203	7.3	1420	1.8	2.7	
132	M3BP 355 SMA	3GBP 354 210-••G	744	95.5	95.3	0.80	250	7.5	1694	1.5	2.6	
160	M3BP 355 SMB	3GBP 354 220-••G	744	95.6	95.5	0.80	305	7.6	2054	1.6	2.6	
200	M3BP 355 SMC	3GBP 354 230-••G	743	95.7	95.6	0.80	378	7.4	2570	1.6	2.6	
250	M3BP 355 MLB	3GBP 354 420-••G	743	95.9	95.8	0.80	476	7.5	3213	1.6	2.7	
315 ¹⁾	M3BP 355 LKB	3GBP 354 820-••G	742	95.8	95.8	0.79	600	7.9	4054	1.7	2.7	
315	M3BP 400 LA	3GBP 404 510-••G	744	96.4	96.3	0.81	582	7.0	4043	1.2	2.6	
315 ³⁾	M3BP 400 LKA	3GBP 404 810-••G	744	96.4	96.3	0.81	582	7.0	4043	1.2	2.6	
355	M3BP 400 LB	3GBP 404 520-••G	743	96.4	96.3	0.82	650	6.8	4563	1.2	2.5	
355 ³⁾	M3BP 400 LKB	3GBP 404 820-••G	743	96.4	96.3	0.82	650	6.8	4563	1.2	2.5	
400	M3BP 400 LC	3GBP 404 530-••G	744	96.6	96.5	0.82	735	7.4	5134	1.3	2.7	
400 ³⁾	M3BP 400 LKC	3GBP 404 830-••G	744	96.6	96.5	0.82	735	7.4	5134	1.3	2.7	
750 r/min = 8 poles			400 V 50 Hz				High-output design					
8.5 ¹⁾	M3BP 160 LB	3GBP 164 104-••A	700	83.5	85.0	0.70	21	5.1	115	2.4	2.5	
15 ¹⁾	M3BP 180 LB	3GBP 184 102-••A	720	88.0	89.2	0.76	32.5	6.0	199	2.5	2.6	
18.5 ¹⁾	M3BP 200 MLB	3GBP 204 002-••A	735	91.4	91.4	0.81	36	6.7	237	1.7	2.8	
30 ¹⁾	M3BP 225 SMC	3GBP 224 003-••A	735	91.8	92.5	0.79	64	6.9	390	2.9	3.3	
37	M3BP 250 SMB	3GBP 254 002-••A	735	93.2	93.5	0.81	74	7.8	481	3.1	3.5	
55	M3BP 280 SMC	3GBP 284 230-••G	741	94.4	94.3	0.80	105	7.9	709	1.9	3.1	
132	M3BP 315 LKA	3GBP 314 810-••G	740	95.1	95.2	0.83	243	7.3	1703	1.8	2.6	
150	M3BP 315 LKB	3GBP 314 820-••G	741	95.3	95.3	0.83	275	7.7	1933	1.9	2.7	
160	M3BP 315 LKC	3GBP 314 830-••G	740	95.3	95.4	0.83	292	7.7	2065	1.9	2.8	

¹⁾ Temperature rise class F.

²⁾ Temperature rise class F at 380 V 50 Hz.

³⁾ Size with alternative dimensions

The two bullets in the product code indicate choice of mounting arrangement, voltage and frequency (see ordering information page).

LV Process performance cast iron motors

Technical data for totally enclosed squirrel cage three phase motors

IP 55 – IC 411 – Insulation class F, temperature rise class B

Output kW	Motor type	Speed r/min	Efficiency %	Power factor cos φ	Current I _N A	Speed r/min	Efficiency %	Power factor cos φ	Current I _N A	Moment of inertia J = ¼ GD ² kgm ²	Weight kg	Sound pressure level L _p dB(A)
750 r/min = 8 poles		380 V 50 Hz				415 V 50 Hz				Basic design		
4	M3BP 160 MA	710	83.8	0.71	10.2	720	84.5	0.66	9.9	0.072	100	59
5.5 ²⁾	M3BP 160 M	705	84.0	0.72	13.8	715	85.0	0.68	13.3	0.091	113	59
7.5 ²⁾	M3BP 160 L	710	85.7	0.72	18.6	715	86.6	0.68	17.8	0.131	126	59
11	M3BP 180 L	715	88.2	0.77	24.5	720	89.0	0.75	23	0.224	177	59
15	M3BP 200 MLA	735	91.0	0.83	30	740	91.2	0.79	29	0.45	250	60
18.5	M3BP 225 SMA	730	91.0	0.79	39	735	91.3	0.76	36	0.61	305	63
22	M3BP 225 SMB	730	91.4	0.81	45	735	91.5	0.76	44	0.68	320	63
30	M3BP 250 SMA	735	92.6	0.81	61	740	92.9	0.77	58	1.25	415	63
37	M3BP 280 SMA	740	93.4	0.80	75	742	93.4	0.76	73	1.85	605	65
45	M3BP 280 SMB	740	93.9	0.80	91	742	94.0	0.75	89	2.2	645	65
55	M3BP 315 SMA	741	93.9	0.83	108	743	94.1	0.79	103	3.2	830	62
75	M3BP 315 SMB	740	94.2	0.83	147	742	94.4	0.81	137	4.1	930	62
90	M3BP 315 SMC	740	94.6	0.84	173	742	94.8	0.81	164	4.9	1000	64
110	M3BP 315 MLA	739	94.9	0.84	210	741	95.0	0.81	198	5.8	1150	72
132	M3BP 355 SMA	743	95.4	0.82	257	745	95.5	0.78	247	7.9	1520	69
160	M3BP 355 SMB	743	95.5	0.82	310	745	95.6	0.78	300	9.7	1680	69
200	M3BP 355 SMC	742	95.6	0.81	398	744	95.7	0.78	373	11.3	1820	69
250 ²⁾	M3BP 355 MLB	741	95.6	0.81	490	743	95.9	0.78	468	13.5	2180	72
315 ²⁾	M3BP 355 LKB	741	95.7	0.81	625	743	95.8	0.78	590	16.5	2600	75
315	M3BP 400 LA	743	96.4	0.82	608	744	96.4	0.79	580	17	2900	71
315 ³⁾	M3BP 400 LKA	743	96.4	0.82	608	744	96.4	0.79	580	17	2900	71
355 ²⁾	M3BP 400 LB	742	96.3	0.83	680	744	96.5	0.81	630	21	3200	71
355 ²⁾³⁾	M3BP 400 LKB	742	96.3	0.83	680	744	96.5	0.81	630	21	3200	71
400 ²⁾	M3BP 400 LC	743	96.5	0.83	765	744	96.6	0.80	720	24	3400	71
400 ²⁾³⁾	M3BP 400 LKC	743	96.5	0.83	765	744	96.6	0.80	720	24	3400	71
750 r/min = 8 poles		380 V 50 Hz				415 V 50 Hz				High-output design		
8.5 ²⁾	M3BP 160 LB	695	81.7	0.73	21.5	705	83.8	0.68	21	0.131	128	62
15 ²⁾	M3BP 180 LB	715	87.6	0.78	33.5	720	88.3	0.74	32	0.24	185	62
18.5 ²⁾	M3BP 200 MLB	735	91.2	0.83	37	735	91.6	0.79	35	0.54	275	60
30 ²⁾	M3BP 225 SMC	730	91.7	0.80	65	735	91.9	0.77	63	0.8	345	63
37	M3BP 250 SMB	735	92.5	0.82	77	735	93.2	0.81	73	1.52	460	63
55	M3BP 280 SMC	739	94.2	0.82	108	742	94.4	0.78	104	2.85	725	65
132	M3BP 315 LKA	739	95.0	0.84	251	741	95.2	0.82	238	7.3	1410	74
150	M3BP 315 LKB	739	95.2	0.84	287	741	95.3	0.82	270	8.3	1520	74
160 ²⁾	M3BP 315 LKC	738	95.2	0.84	305	741	95.4	0.82	285	9.2	1600	75

LV Process performance cast iron motors

Technical data for totally enclosed squirrel cage three phase motors, two-speed

IP 55 – IC 411 – Insulation class F, temperature rise class F

Output kW	Motor type	Product code	Speed r/min	Efficiency %	Power factor cos φ	Current		Torque			Moment of inertia J = ¼ GD ² kgm ²	Weight kg
						I _N A	I _s I _N	T _N Nm	T _s T _N	T _{max} T _N		
3000/1500 r/min = 2/4 poles 400 V 50 Hz Fan drive, two separate windings												
13/1.9	M3BP 160 M	3GBP 168 352-••A	2940/1470	88.5/79.5	0.92/0.79	23/4.4	7.8/6.4	42/12	2.1/2.1	3.0/2.5	0.054	133
17.5/2.5	M3BP 160 L	3GBP 168 353-••A	2925/1475	89.0/81.0	0.92/0.77	31/5.8	7.1/6.7	57/16	2.0/2.5	2.6/2.9	0.057	140
20/2.8	M3BP 180 M	3GBP 188 357-••A	2930/1465	89.0/77.0	0.90/0.77	36/6.9	6.4/5.8	65/18	2.1/1.9	2.4/2.0	0.094	194
25/3.6	M3BP 180 L	3GBP 188 358-••A	2940/1465	90.0/78.0	0.88/0.78	46/8.6	7.5/7.3	81/24	2.6/1.9	2.9/1.9	0.108	200
30/4.1	M3BP 200 MLA	3GBP 208 210-••A	2945/1480	91.5/85.0	0.89/0.72	54/10	8.0/7.1	97/26	2.2/2.7	2.8/2.8	0.15	250
38/5.5	M3BP 200 MLB	3GBP 208 211-••A	2945/1480	92.5/86.5	0.91/0.74	67/13	7.7/6.8	123/35	2.2/2.6	2.6/2.6	0.19	270
43/6	M3BP 225 SMB	3GBP 228 207-••A	2950/1475	92.5/86.5	0.90/0.78	75/13	7.1/5.8	139/39	2.3/2.7	2.4/2.0	0.26	335
50/7	M3BP 225 SMC	3GBP 228 208-••A	2955/1480	93.0/87.5	0.91/0.78	86/15	7.3/6.1	162/45	2.4/2.9	2.4/2.1	0.29	355
70/10	M3BP 250 SMB	3GBP 258 204-••A	2965/1485	94.0/89.5	0.90/0.76	119/22	9.3/7.1	225/64	2.3/2.5	3.1/2.3	0.57	465
84/12	M3BP 280 SMB	3GBP 288 221-••G	2980/1492	94.6/90.2	0.88/0.74	147/26	8.0/7.3	269/77	2.1/3.1	3.0/2.8	0.9	665
100/15	M3BP 280 SMC	3GBP 288 231-••G	2974/1492	94.5/91.0	0.91/0.75	169/32	6.7/7.3	321/96	1.8/3.2	2.4/2.7	1.15	725
125/18	M3BP 315 SMB	3GBP 318 221-••G	2983/1493	95.0/91.9	0.87/0.73	220/39	7.5/6.3	400/115	2.1/2.8	2.9/2.4	1.4	940
150/22	M3BP 315 SMC	3GBP 318 231-••G	2976/1492	95.2/92.4	0.89/0.74	257/47	5.9/6.2	481/141	1.7/2.8	2.1/2.3	1.7	1025
190/27	M3BP 315 MLA	3GBP 318 411-••G	2981/1492	95.8/93.1	0.89/0.74	322/57	7.8/6.7	609/173	2.5/3.2	2.8/2.5	2.1	1190
220/30	M3BP 355 SMA	3GBP 358 211-••G	2982/1491	95.8/91.6	0.90/0.78	370/61	6.8/6.6	705/192	1.3/2.4	2.8/2.4	3	1600
350/45	M3BP 355 MLA	3GBP 358 411-••G	2982/1493	96.4/93.2	0.88/0.68	600/102	7.3/7.2	1121/288	2.0/2.8	2.6/2.9	4.1	2000
3000/1500 r/min = 2 - 4 poles 400 V 50 Hz Fan drive, Dahlander-connection												
10/2	M3BP 160 MA	3GBP 168 301-••A	2910/1465	85.0/83.5	0.89/0.73	19/4.8	5.9/6.1	30/43	1.5/2.4	2.3/2.8	0.039	118
16/3.2	M3BP 160 M	3GBP 168 302-••A	2915/1465	87.5/86.5	0.92/0.76	28.5/7	6.6/6.3	52/21	1.8/2.5	2.4/2.8	0.054	133
19.5/4.5	M3BP 160 L	3GBP 168 303-••A	2930/1465	89.0/88.0	0.89/0.77	36/9.7	7.6/6.4	64/29	2.3/2.5	2.9/2.8	0.057	140
21.5/4.7	M3BP 180 M	3GBP 188 305-••A	2935/1465	90.0/88.0	0.91/0.77	38/10	7.0/5.3	70/28	2.1/2.1	2.6/2.3	0.094	194
26/5.2	M3BP 180 L	3GBP 188 306-••A	2940/1470	90.5/89.5	0.89/0.75	47/11	6.9/5.8	85/34	2.3/2.4	2.6/2.4	0.108	200
32/8	M3BP 200 MLA	3GBP 208 110-••A	2940/1465	90.0/89.5	0.89/0.85	58/16	7.1/6.2	104/52	2.0/2.0	2.5/2.2	0.28	255
39/10	M3BP 200 MLB	3GBP 208 111-••A	2950/1475	91.5/91.0	0.89/0.85	69/19	7.4/6.2	126/65	2.0/2.0	2.6/2.3	0.34	275
42/11	M3BP 200 MLC	3GBP 208 112-••A	2950/1470	92.5/91.0	0.89/0.77	75/23	7.7/5.6	136/71	2.2/2.1	3.0/2.5	0.19	280
45/13	M3BP 225 SMB	3GBP 228 107-••A	2955/1475	93.0/91.5	0.92/0.82	76/25	7.4/5.3	145/84	2.0/2.0	2.6/2.1	0.27	335
55/15	M3BP 225 SMC	3GBP 228 108-••A	2955/1475	93.5/92.5	0.91/0.82	94/29	7.3/5.4	178/97	2.0/2.0	2.6/2.2	0.3	355
75/25	M3BP 250 SMB	3GBP 258 104-••A	2965/1475	94.5/93.0	0.92/0.82	125/48	8.9/5.5	241/162	2.3/2.0	3.1/2.2	0.36	465
90/30	M3BP 280 SMB	3GBP 288 228-••G	2965/1484	93.5/93.6	0.91/0.86	153/54	7.3/5.8	290/193	1.4/1.7	3.0/2.2	1.5	665
105/33	M3BP 280 SMC	3GBP 288 238-••G	2966/1483	93.5/93.9	0.87/0.85	186/60	7.4/5.7	338/212	1.6/1.7	3.1/2.3	1.85	725
125/25	M3BP 315 SMB	3GBP 318 228-••G	2972/1490	94.9/94.5	0.88/0.73	217/53	6.1/5.4	402/160	1.8/2.4	2.3/2.0	1.4	940
175/45	M3BP 315 MLA	3GBP 318 418-••G	2980/1492	95.4/95.4	0.93/0.84	287/81	9.6/8.9	561/288	2.4/2.9	3.6/3.4	3.5	1160
260/65	M3BP 355 SMB	3GBP 358 228-••G	2983/1491	95.9/95.0	0.88/0.70	450/140	7.5/5.5	832/416	1.6/1.9	2.7/2.1	3.4	1680
320/80	M3BP 355 MLA	3GBP 358 418-••G	2983/1492	96.2/95.7	0.90/0.75	540/160	8.0/6.7	1024/512	1.6/2.1	3.0/2.6	4.1	2000
400/100	M3BP 355 LKA	3GBP 358 818-••G	2983/1492	96.5/96.0	0.90/0.75	670/200	8.0/6.4	1280/640	1.7/2.0	3.0/2.5	4.8	2320

Data for other sizes on request.

The two bullets in the product code indicate choice of mounting arrangement, voltage and frequency (see ordering information page).

LV Process performance cast iron motors

Technical data for totally enclosed squirrel cage three phase motors, two-speed

IP 55 – IC 411 – Insulation class F, temperature rise class F

Output kW	Motor type	Product code	Speed r/min	Efficiency %	Power factor cos φ	Current		Torque			Moment of inertia J = ¼ GD ² kgm ²	Weight kg
						I _N A	I _s I _N	T _N Nm	T _s T _N	T _{max} T _N		
1500/1000 r/min = 4/6 poles			400 V 50 Hz			Fan drive, two separate windings						
10.5/3.5	M3BP 160 M	3GBP 168 354-••A	1460/965	87.0/75.5	0.84/0.78	21/8.6	6.4/4.1	69/35	2.0/1.3	2.5/1.7	0.089	127
14.5/4.5	M3BP 160 L	3GBP 168 355-••A	1460/970	88.5/77.0	0.85/0.76	28/11	6.9/4.6	95/44	2.2/1.5	2.6/1.9	0.119	148
16/5	M3BP 180 M	3GBP 188 359-••A	1470/980	89.0/78.0	0.83/0.73	31/12.5	6.3/4.6	104/49	1.9/1.5	2.5/2.0	0.176	194
20/6.5	M3BP 180 L	3GBP 188 360-••A	1470/980	90.0/79.5	0.83/0.74	39/16	7.2/5.0	130/63	2.4/1.8	2.7/2.0	0.224	207
23/7.2	M3BP 200 MLA	3GBP 208 213-••A	1475/985	89.5/84.0	0.88/0.87	43/15	7.7/7.8	149/70	1.6/1.9	2.8/2.9	0.44	250
30/9	M3BP 200 MLB	3GBP 208 214-••A	1470/985	90.0/83.5	0.90/0.89	54/18	7.7/6.3	195/87	1.6/1.2	2.7/2.1	0.53	275
34/11	M3BP 225 SMB	3GBP 228 209-••A	1470/985	91.0/85.0	0.91/0.89	60/21	7.7/6.7	221/107	1.5/1.3	2.7/2.3	0.67	320
42/14	M3BP 225 SMC	3GBP 228 210-••G	1475/985	91.5/89.0	0.89/0.89	75/27	8.4/6.8	272/136	1.7/1.4	3.0/2.3	0.78	345
63/18.5	M3BP 250 SMB	3GBP 258 205-••A	1475/985	93.5/87.0	0.89/0.79	110/40	7.5/7.3	408/179	2.4/3.0	2.7/2.6	0.89	465
85/27	M3BP 280 SMB	3GBP 288 224-••G	1487/992	94.3/90.4	0.82/0.73	160/59	7.5/7.3	546/260	2.7/3.2	3.1/3.1	1.5	665
100/30	M3BP 280 SMC	3GBP 288 234-••G	1486/991	94.7/90.6	0.85/0.77	180/62	7.3/6.6	643/289	2.5/2.8	2.9/2.6	1.85	725
120/36	M3BP 315 SMB	3GBP 318 224-••G	1487/991	95.1/91.4	0.86/0.79	212/72	6.2/6.0	771/347	1.8/2.3	2.3/2.5	2.6	960
145/43	M3BP 315 SMC	3GBP 318 234-••G	1487/991	95.3/92.4	0.86/0.79	256/86	6.3/6.2	931/414	1.8/2.5	2.3/2.5	2.9	1000
180/54	M3BP 315 MLA	3GBP 318 414-••G	1484/990	95.5/92.0	0.86/0.79	321/109	6.1/6.0	1158/521	1.9/2.5	2.5/2.5	3.6	1160
210/63	M3BP 315 LKA	3GBP 318 814-••G	1486/990	95.2/91.3	0.86/0.79	372/127	6.4/6.2	1349/608	2.0/2.7	2.6/2.6	4.4	1410
250/75	M3BP 315 LKB	3GBP 318 824-••G	1487/992	95.6/92.4	0.85/0.77	445/155	7.7/7.2	1605/722	2.5/3.3	3.1/3.0	5	1520
220/65	M3BP 355 SMA	3GBP 358 214-••G	1489/991	95.9/93.5	0.85/0.77	390/131	6.3/6.3	1411/626	1.6/2.4	2.5/2.3	5.9	1610
300/90	M3BP 355 SMC	3GBP 358 234-••G	1488/991	96.0/94.2	0.86/0.76	525/183	6.3/6.9	1925/867	1.7/2.8	2.4/2.5	7.2	1820
390/110	M3BP 355 MLB	3GBP 358 424-••G	1490/992	96.4/94.5	0.84/0.77	700/221	7.4/7.1	2499/1059	2.2/2.9	2.9/2.5	8.4	2140
1500/750 r/min = 4/8 poles			400 V 50 Hz			Fan drive, two separate windings						
9/1.3	M3BP 160 M	3GBP 168 356-••A	1460/735	87.0/60.0	0.84/0.53	18/5.9	6.6/4.0	59/17	2.0/2.2	2.5/2.7	0.089	127
13/1.8	M3BP 160 L	3GBP 168 357-••A	1455/735	88.0/64.0	0.85/0.53	26/8.2	6.0/4.1	89/26	1.9/2.2	2.3/2.6	0.119	148
16/2.3	M3BP 180 M	3GBP 188 361-••A	1475/740	88.5/64.0	0.82/0.53	32/9.7	6.8/4.1	104/30	2.2/2.2	2.7/2.6	0.176	194
19/2.7	M3BP 180 L	3GBP 188 362-••A	1475/740	89.5/68.0	0.83/0.54	37/10.5	7.5/7.2	123/35	2.6/2.6	2.9/2.6	0.224	207
26/3.3	M3BP 200 MLA	3GBP 208 216-••A	1475/740	91.0/73.0	0.85/0.59	49/11	6.9/4.6	168/46	2.1/2.2	2.5/2.3	0.28	255
30/3.8	M3BP 200 MLB	3GBP 208 217-••A	1470/740	91.5/75.5	0.86/0.59	55/12.5	6.7/4.6	195/49	2.1/2.2	2.4/2.2	0.34	275
38/5.2	M3BP 225 SMB	3GBP 228 211-••A	1480/740	91.5/80.5	0.84/0.63	72/15	7.3/5.2	245/67	2.1/2.3	2.6/2.3	0.41	330
46/7	M3BP 225 SMC	3GBP 228 212-••A	1480/740	92.5/82.0	0.86/0.66	85/19	7.7/4.9	297/90	2.3/2.1	2.7/2.1	0.49	355
63/10	M3BP 250 SMB	3GBP 258 206-••A	1475/740	93.5/83.0	0.89/0.65	110/27	7.5/6.0	408/129	2.4/3.0	2.7/2.7	0.89	465
85/12	M3BP 280 SMB	3GBP 288 222-••G	1487/744	94.3/85.5	0.82/0.60	160/34	7.5/5.3	546/154	2.7/3.5	3.1/2.4	1.5	665
100/15	M3BP 280 SMC	3GBP 288 232-••G	1486/744	94.7/86.5	0.85/0.62	180/40	7.3/5.4	643/193	2.5/3.4	2.9/2.3	1.85	725
120/18	M3BP 315 SMB	3GBP 318 222-••G	1487/744	95.1/87.8	0.86/0.67	212/41	6.2/4.5	771/205	1.8/2.1	2.3/2.1	2.6	960
145/19	M3BP 315 SMC	3GBP 318 232-••G	1487/744	95.3/88.9	0.86/0.64	256/48	6.3/4.8	931/244	1.8/2.3	2.3/2.1	2.9	1000
180/23	M3BP 315 MLA	3GBP 318 412-••G	1484/743	95.5/89.2	0.86/0.57	321/58	6.1/4.9	1158/296	1.9/2.5	2.5/2.2	3.6	1160
210/27	M3BP 315 LKA	3GBP 318 812-••G	1486/743	95.2/88.8	0.86/0.63	372/70	6.4/4.9	1349/347	2.0/2.6	2.6/2.2	4.4	1410
250/32	M3BP 315 LKB	3GBP 318 822-••G	1487/744	95.6/89.8	0.85/0.63	445/81	7.7/5.0	1605/411	2.5/2.6	3.1/2.2	5	1520
220/28	M3BP 355 SMA	3GBP 358 212-••G	1489/744	95.9/91.4	0.85/0.63	390/70	6.3/5.5	1411/359	1.6/2.0	2.5/2.2	5.9	1610
300/38	M3BP 355 SMC	3GBP 358 232-••G	1488/745	96.0/92.0	0.86/0.62	525/96	6.3/6.1	1925/487	1.7/2.3	2.4/2.3	7.2	1820
390/50	M3BP 355 MLB	3GBP 358 422-••G	1490/744	96.4/92.6	0.84/0.64	700/123	7.4/5.9	2499/642	2.2/2.2	2.9/2.1	8.4	2140

Data for other sizes on request.

The two bullets in the product code indicate choice of mounting arrangement, voltage and frequency (see ordering information page).

LV Process performance cast iron motors

Technical data for totally enclosed squirrel cage three phase motors, two-speed

IP 55 – IC 411 – Insulation class F, temperature rise class F

Output kW	Motor type	Product code	Speed r/min	Efficiency %	Power factor cos φ	Current		Torque			Moment of inertia J = ¼ GD ² kgm ²	Weight kg																										
						I _N A	I _s I _N	T _N Nm	T _s T _N	T _{max} T _N																												
1500/750 r/min = 4 - 8 poles													400 V 50 Hz													Fan drive, Dahlander-connection												
10.5/2.2	M3BP	160 M	3GBP	168 304-••A	1460/735	87.5/79.0	0.84/0.54	21/7.4	6.9/3.7	69/29	2.2/1.5	2.7/2.3	0.089	127																								
15.5/2.7	M3BP	160 L	3GBP	168 305-••A	1460/735	88.5/79.5	0.85/0.51	30/9.5	6.9/3.9	101/35	2.2/1.7	2.6/2.6	0.119	148																								
17/3.4	M3BP	180 M	3GBP	188 307-••A	1470/730	88.5/78.0	0.85/0.56	33/11	5.8/4.3	111/44	1.7/1.2	2.3/1.9	0.176	194																								
22/4.4	M3BP	180 L	3GBP	188 308-••A	1475/735	89.5/79.0	0.83/0.53	43/15	6.7/3.9	143/57	2.0/1.7	2.6/2.3	0.224	207																								
29/6.5	M3BP	200 MLA	3GBP	208 116-••A	1470/730	90.5/86.0	0.86/0.64	54/17	6.9/4.2	188/81	2.2/1.9	2.4/1.9	0.28	255																								
33/8	M3BP	200 MLB	3GBP	208 117-••A	1475/730	91.5/86.5	0.86/0.64	61/21	7.8/4.2	214/105	2.6/1.9	2.6/1.8	0.34	275																								
42/10	M3BP	225 SMB	3GBP	228 111-••A	1480/740	92.0/89.5	0.86/0.64	85/27	7.8/5.0	271/129	2.5/2.2	3.0/2.3	0.49	335																								
50/11	M3BP	225 SMC	3GBP	228 112-••A	1465/735	92.5/89.5	0.87/0.65	91/28	7.3/4.7	324/143	2.3/2.0	2.5/2.0	0.49	355																								
60/15	M3BP	250 SMB	3GBP	258 106-••A	1475/735	93.0/90.0	0.86/0.70	104/34	7.9/4.7	388/195	2.6/2.1	2.7/2.0	0.89	465																								
80/18.5	M3BP	280 SMB	3GBP	288 229-••G	1486/743	94.1/91.5	0.85/0.62	145/47	7.6/5.2	514/238	2.6/2.5	3.1/2.3	1.5	665																								
90/20	M3BP	280 SMC	3GBP	288 239-••G	1486/743	94.4/91.9	0.87/0.62	160/50	7.8/5.2	578/257	2.7/2.5	3.1/2.3	1.85	725																								
125/28	M3BP	315 SMB	3GBP	318 229-••G	1488/744	95.1/92.6	0.84/0.60	226/73	7.0/4.3	802/359	2.3/2.1	2.9/2.3	2.6	960																								
160/37	M3BP	315 MLA	3GBP	318 419-••G	1486/742	95.0/92.8	0.86/0.62	283/93	6.8/4.0	1028/476	2.4/2.0	2.8/2.1	3.5	1160																								
200/50	M3BP	315 LKA	3GBP	318 819-••G	1487/742	94.9/92.9	0.86/0.62	354/125	7.4/3.9	1284/643	2.8/2.0	3.1/2.0	4.4	1410																								
260/65	M3BP	315 LKC	3GBP	318 839-••G	1489/743	95.3/93.5	0.85/0.60	470/165	8.5/4.3	1667/835	3.5/2.3	3.6/2.3	5.5	1600																								
220/50	M3BP	355 SMA	3GBP	358 219-••G	1489/744	95.7/94.3	0.85/0.61	395/126	7.2/4.6	1411/642	2.1/1.6	2.9/2.0	5.9	1610																								
300/70	M3BP	355 SMC	3GBP	358 239-••G	1490/744	96.0/94.6	0.85/0.60	536/177	8.3/5.0	1923/898	2.6/1.8	3.3/2.1	7.2	1820																								
1000/750 r/min = 6/8 poles													400 V 50 Hz													Fan drive, two separate windings												
177.5	M3BP	200 MLB	3GBP	208 221-••A	985/740	88.0/81.5	0.85/0.77	33/17	7.1/6.4	165/97	2.2/2.2	2.5/2.5	0.42	260																								
20/9	M3BP	200 MLC	3GBP	208 222-••A	985/740	88.5/82.5	0.84/0.74	39/21	7.6/7.0	194/116	2.4/2.6	2.7/2.9	0.48	275																								
26/12	M3BP	225 SMB	3GBP	228 215-••A	985/740	89.5/84.5	0.85/0.76	49/27	7.4/7.1	252/155	2.2/2.4	2.5/2.7	0.63	320																								
32/14	M3BP	225 SMC	3GBP	228 216-••A	985/740	90.5/85.5	0.83/0.76	62/31	7.0/7.2	310/180	2.4/2.5	2.4/2.5	0.74	345																								
43/15	M3BP	250 SMB	3GBP	258 208-••A	990/745	91.0/86.0	0.84/0.75	81/34	7.3/7.4	415/198	2.2/2.7	2.5/2.8	1.41	460																								
53/20	M3BP	280 SMB	3GBP	288 226-••G	990/745	93.4/88.0	0.84/0.72	99/46	6.4/7.2	511/256	2.2/3.0	2.4/2.6	2.2	645																								
70/26	M3BP	280 SMC	3GBP	288 236-••G	992/745	94.1/90.0	0.81/0.73	132/58	7.9/7.3	674/333	2.7/3.2	2.8/2.6	2.85	725																								
84/36	M3BP	315 SMB	3GBP	318 226-••G	993/745	94.3/90.8	0.83/0.74	156/78	7.2/7.2	808/461	1.9/2.7	2.4/3.0	4.1	930																								
103/44	M3BP	315 SMC	3GBP	318 236-••G	993/745	94.5/91.5	0.81/0.75	195/94	7.9/7.0	991/564	2.2/2.7	2.6/2.8	4.9	1000																								
123/52	M3BP	315 MLA	3GBP	318 416-••G	993/745	94.8/92.0	0.82/0.75	230/109	7.6/7.3	1183/667	2.1/2.8	2.5/2.8	5.8	1150																								
140/60	M3BP	315 LKA	3GBP	318 816-••G	993/745	94.7/92.5	0.83/0.74	260/127	7.6/7.9	1346/769	2.1/3.1	2.4/3.0	7.3	1410																								
158/67	M3BP	315 LKB	3GBP	318 826-••G	993/745	94.9/92.7	0.84/0.74	288/142	7.6/8.0	1519/859	2.1/3.2	2.4/3.0	8.3	1520																								
180/76	M3BP	315 LKC	3GBP	318 836-••G	993/745	95.1/92.9	0.83/0.73	330/163	8.1/8.4	1731/974	2.3/3.5	2.5/3.2	9.2	1600																								
140/60	M3BP	355 SMA	3GBP	358 216-••G	994/745	95.3/93.0	0.81/0.75	263/125	7.3/7.4	1345/769	2.0/2.6	2.6/2.5	7.9	1520																								
180/76	M3BP	355 SMB	3GBP	358 226-••G	994/745	95.5/93.3	0.81/0.75	317/157	7.5/7.3	1729/974	2.2/2.7	2.7/2.5	9.7	1680																								
210/88	M3BP	355 SMC	3GBP	358 236-••G	994/745	95.6/93.5	0.82/0.76	390/178	7.3/7.0	2017/1128	2.2/2.6	2.6/2.4	11.3	1820																								
250/105	M3BP	355 MLB	3GBP	358 426-••G	994/744	95.6/93.4	0.81/0.75	463/218	7.3/6.6	2402/1348	2.3/2.6	2.7/2.4	13.5	2180																								
315/132	M3BP	355 LKB	3GBP	358 826-••G	993/745	95.8/93.7	0.81/0.71	583/290	6.9/8.3	3029/1692	2.2/3.6	2.5/3.0	16.5	2600																								
355/150	M3BP	400 LB	3GBP	408 526-••G	995/745	96.2/94.7	0.80/0.76	670/300	7.0/6.8	3407/1923	1.6/1.9	2.6/2.2	20.5	3150																								
355/150	M3BP	400 LKB	3GBP	408 826-••G	995/745	96.2/94.7	0.80/0.76	670/300	7.0/6.8	3407/1923	1.6/1.9	2.6/2.2	20.5	3150																								
400/170	M3BP	400 LD	3GBP	408 546-••G	995/746	96.3/94.9	0.82/0.75	740/350	6.8/7.4	3839/2176	1.5/2.2	2.5/2.4	24	3400																								
400/170	M3BP	400 LKD	3GBP	408 846-••G	995/746	96.3/94.9	0.82/0.75	740/350	6.8/7.4	3839/2176	1.5/2.2	2.5/2.4	24	3400																								

Data for other sizes on request.

The two bullets in the product code indicate choice of mounting arrangement, voltage and frequency (see ordering information page).

LV Process performance cast iron motors

Technical data for totally enclosed squirrel cage three phase motors, two-speed

IP 55 – IC 411 – Insulation class F, temperature rise class F

Output kW	Motor type	Product code	Speed r/min	Effi- ciency %	Power factor cos φ	Current		Torque			Moment of inertia J = ¼ GD ² kgm ²	Weight kg
						I _N A	I _s I _N	T _N Nm	T _s T _N	T _{max} T _N		
3000/1500 r/min = 2/4 poles			400 V 50 Hz			Constant torque, two separate windings						
12/6	M3BP 160 M	3GBP 168 359-***A	2835/1460	87.5/84.5	0.92/0.8	22/13	7.7/6.0	39/39	2.1/2.3	2.8/2.4	0.054	133
15/7.5	M3BP 160 L	3GBP 168 360-***A	2940/1460	88.5/84.5	0.93/0.78	27/16.5	7.9/6.0	49/49	2.2/2.4	2.9/2.4	0.057	140
18/9	M3BP 180 L	3GBP 188 352-***A	2945/1460	89.0/84.0	0.9/0.77	32/20	7.7/5.2	58/59	2.5/2.3	2.8/2.1	0.108	200
23/12	M3BP 200 MLA	3GBP 208 201-***A	2960/1475	90.0/89.0	0.89/0.85	42/23	7.8/7.4	74/77	1.7/2.2	2.8/2.5	0.28	255
30/16	M3BP 200 MLB	3GBP 208 202-***A	2960/1475	91.0/90.0	0.9/0.87	53/30	8.2/7.3	97/104	1.8/2.2	2.9/2.5	0.34	275
36/18	M3BP 225 SMB	3GBP 228 201-***A	2960/1480	91.5/91.5	0.91/0.76	63/38	8.0/7.2	116/116	2.5/3.8	2.7/2.5	0.26	335
40/20	M3BP 225 SMC	3GBP 228 202-***A	2960/1475	92.0/91.5	0.91/0.79	69/41	8.5/6.5	129/129	2.8/3.3	2.8/2.2	0.29	355
50/25	M3BP 250 SMB	3GAA 258 201-***A	2965/1485	93.0/93.0	0.91/0.76	86/52	8.9/8.5	161/161	2.1/3.5	2.9/2.9	0.57	465
65/33	M3BP 280 SMB	3GBP 289 221-***G	2979/1488	93.5/93.2	0.89/0.77	112/67	7.5/6.7	208/212	1.8/2.8	2.7/2.5	0.9	665
82/41	M3BP 280 SMC	3GBP 289 231-***G	2979/1488	94.1/93.9	0.9/0.78	141/81	7.8/7.2	263/263	2.1/3.1	2.7/2.6	1.15	725
100/50	M3BP 315 SMB	3GBP 319 221-***G	2986/1488	94.0/94.2	0.85/0.76	183/101	8.6/5.8	320/321	2.3/2.5	3.3/2.3	1.4	940
125/63	M3BP 315 SMC	3GBP 319 231-***G	2980/1490	94.6/94.1	0.89/0.75	216/128	6.7/6.6	401/404	1.8/3.0	2.4/2.5	1.7	1025
155/78	M3BP 315 MLA	3GBP 319 411-***G	2985/1489	95.2/94.5	0.89/0.76	267/157	8.9/6.3	496/500	2.6/3.0	3.2/2.5	2.1	1190
180/90	M3BP 355 SMA	3GBP 359 211-***G	2985/1490	95.3/94.9	0.89/0.78	308/175	7.7/7.0	576/577	1.4/2.5	3.2/2.9	3	1600
300/150	M3BP 355 MLA	3GBP 359 411-***G	2985/1491	96.0/95.5	0.88/0.69	512/328	8.0/7.5	960/961	2.0/3.0	2.9/2.9	4.1	2000
3000/1500 r/min = 2 - 4 poles			400 V 50 Hz			Constant torque, Dahlander-connection						
9/6.5	M3BP 160 MA	3GBP 168 306-***A	2885/1440	83.0/82.0	0.92/0.74	17.1/15.6	4.6/4.3	40/43	1.3/1.7	1.9/1.9	0.039	118
12.5/9	M3BP 160 M	3GBP 168 307-***A	2890/1440	85.5/85.5	0.93/0.8	22.5/19	5.2/4.6	41/60	1.4/1.8	1.9/1.9	0.054	133
15/10.5	M3BP 160 L	3GBP 168 308-***A	2900/1445	87.0/86.0	0.93/0.77	27/23	5.8/4.9	49/69	1.6/2.1	2.1/2.1	0.057	140
18/12	M3BP 180 M	3GBP 188 301-***A	2940/1455	89.0/89.0	0.88/0.79	33/25	6.8/5.3	59/79	2.1/2.4	2.6/2.2	0.094	194
24/17	M3BP 180 L	3GBP 188 302-***A	2945/1455	90.0/90.0	0.89/0.8	43/34	7.4/5.2	78/111	2.4/2.4	2.8/2.1	0.108	200
32/24	M3BP 200 MLA	3GBP 208 101-***A	2940/1470	89.0/90.5	0.89/0.86	58/45	6.8/5.9	104/156	1.8/2.1	2.4/2.1	0.28	255
39/29	M3BP 200 MLB	3GBP 208 102-***A	2950/1470	90.5/91.0	0.84/0.86	75/53	6.8/7.0	126/188	1.7/2.2	2.6/2.4	0.34	275
42/32	M3BP 225 SMB	3GBP 228 101-***A	2955/1475	92.5/93.0	0.92/0.88	71/57	7.1/6.5	136/207	1.5/1.9	2.5/2.3	0.49	330
50/40	M3BP 225 SMC	3GBP 228 102-***A	2960/1475	92.5/93.0	0.84/0.87	94/71	7.4/7.1	161/259	1.8/2.0	2.8/2.5	0.49	355
68/50	M3BP 250 SMB	3GBP 258 101-***A	2940/1475	93.0/93.5	0.93/0.88	113/87	6.6/6.9	220/324	1.5/2.1	2.4/2.5	0.89	465
90/65	M3BP 280 SMB	3GBP 289 228-***G	2965/1488	93.5/94.8	0.91/0.85	153/117	7.3/8.6	290/417	1.4/2.8	3.0/3.3	1.5	665
105/75	M3BP 280 SMC	3GBP 289 238-***G	2966/1486	93.5/94.9	0.87/0.84	186/136	7.4/8.2	338/482	1.6/2.6	3.1/3.3	1.85	725
125/85	M3BP 315 SMB	3GBP 319 228-***G	2972/1485	94.9/95.0	0.88/0.73	217/178	6.1/5.3	402/547	1.8/2.6	2.3/2.1	1.4	940
175/120	M3BP 315 MLA	3GBP 319 418-***G	2980/1491	95.4/96.0	0.93/0.81	287/223	9.6/9.9	561/769	2.4/3.7	3.6/4.0	3.5	1160
250/160	M3BP 355 SMC	3GBP 359 238-***G	2982/1491	95.9/95.7	0.88/0.63	430/383	7.5/6.4	801/1025	1.6/2.7	2.7/2.6	3.6	1750
310/200	M3BP 355 MLB	3GBP 359 428-***G	2983/1491	96.3/96.2	0.91/0.71	510/425	8.1/7.5	992/1281	1.6/2.6	3.0/3.2	4.3	2080
380/250	M3BP 355 LKB	3GBP 359 828-***G	2982/1490	96.5/96.5	0.91/0.73	630/515	7.9/7.2	1217/1602	1.7/2.5	3.0/3.0	5.2	2460

Data for other sizes on request.

The two bullets in the product code indicate choice of mounting arrangement, voltage and frequency (see ordering information page).

LV Process performance cast iron motors

Technical data for totally enclosed squirrel cage three phase motors, two-speed

IP 55 – IC 411 – Insulation class F, temperature rise class F

Output kW	Motor type	Product code	Speed r/min	Efficiency %	Power factor cos φ	Current		Torque			Moment of inertia J = ¼ GD ² kgm ²	Weight kg
						I _N A	I _s I _N	T _N Nm	T _s T _N	T _{max} T _N		
1500/1000 r/min = 4/6 poles 400 V 50 Hz Constant torque, two separate windings												
7.5/5.5	M3BP 160 M	3GBP 168 361-***A	1465/965	85.5/80.5	0.83/0.77	15.5/13	7.1/4.7	49/54	2.1/1.8	2.7/1.9	0.089	127
11.5/8.5	M3BP 160 L	3GBP 168 362-***A	1465/965	86.5/82.5	0.84/0.76	23/19.5	7.0/4.9	75/84	2.1/1.8	2.8/2.0	0.119	148
13/8	M3BP 180 M	3GBP 188 353-***A	1475/975	88.0/82.5	0.82/0.75	26/19	6.5/4.3	84/78	1.9/1.4	2.6/1.8	0.176	194
15/10	M3BP 180 L	3GBP 188 354-***A	1475/975	88.5/84.0	0.83/0.74	30/23	7.1/4.4	97/98	2.3/1.5	2.7/1.9	0.224	207
18/12	M3BP 200 MLA	3GBP 208 204-***A	1475/985	88.5/86.0	0.91/0.86	33/24	7.6/7.8	117/116	2.1/2.6	2.5/2.6	0.42	260
22/14.7	M3BP 200 MLB	3GBP 208 205-***A	1480/985	89.5/86.5	0.89/0.87	40/29	8.2/7.6	142/143	2.4/2.6	2.8/2.5	0.48	275
25/16.7	M3BP 200 MLC	3GBP 208 206-***A	1475/980	89.0/85.5	0.87/0.88	47/32	7.7/6.7	162/162	2.3/2.3	2.6/2.2	0.48	275
32/21	M3BP 225 SMB	3GBP 228 203-***A	1480/985	90.0/89.5	0.88/0.86	58/40	8.6/8.0	206/204	2.3/2.4	2.8/2.7	0.63	320
36/24	M3BP 225 SMC	3GBP 228 204-***A	1480/985	90.5/90.0	0.88/0.87	66/45	8.4/7.4	232/233	2.2/2.2	2.8/2.5	0.74	345
50/32	M3BP 250 SMB	3GBP 258 202-***A	1475/985	92.5/90.5	0.89/0.8	89/65	7.5/7.1	324/310	2.3/3.1	2.6/2.6	0.89	465
65/43	M3BP 280 SMB	3GBP 289 224-***G	1485/988	92.9/91.9	0.86/0.78	117/87	6.6/6.4	418/416	2.0/2.9	2.5/2.4	1.5	665
76/50	M3BP 280 SMC	3GBP 289 234-***G	1487/989	93.7/92.6	0.86/0.78	137/101	7.2/7.4	488/483	2.2/3.3	2.7/2.4	1.85	725
90/60	M3BP 315 SMB	3GBP 319 224-***G	1490/991	94.3/93.6	0.84/0.75	165/125	7.3/6.6	577/578	2.0/2.9	2.8/2.7	2.6	960
110/75	M3BP 315 SMC	3GBP 319 234-***G	1490/992	94.5/93.9	0.84/0.73	200/158	7.3/7.1	705/722	2.0/3.2	2.8/2.8	2.9	1000
140/95	M3BP 315 MLA	3GBP 319 414-***G	1489/990	94.9/93.7	0.85/0.77	250/190	7.2/6.4	898/916	2.1/2.9	2.8/2.5	3.5	1160
170/112	M3BP 315 LKA	3GBP 319 814-***G	1489/992	94.7/93.9	0.85/0.74	305/235	7.1/7.2	1090/1078	2.1/3.5	2.8/3.0	4.4	1410
200/132	M3BP 315 LKC	3GBP 319 824-***G	1491/992	95.1/94.1	0.83/0.74	366/277	8.5/7.4	1281/1271	2.6/3.6	3.4/3.1	5	1520
180/120	M3BP 355 SMA	3GBP 359 214-***G	1491/992	95.4/95.1	0.84/0.74	330/245	6.8/7.5	1153/1155	1.6/2.8	2.7/2.7	5.9	1610
250/167	M3BP 355 SMC	3GBP 359 234-***G	1490/991	95.7/95.2	0.85/0.76	445/335	6.7/6.9	1602/1609	1.6/2.6	2.6/2.4	7.2	1820
330/220	M3BP 355 MLB	3GBP 359 424-***G	1492/992	96.0/95.4	0.83/0.76	605/443	7.8/7.6	2112/2118	2.1/3.0	3.1/2.6	8.4	2140
1500/750 r/min = 4/8 poles 400 V 50 Hz Constant torque, two separate windings												
5.5/2.7	M3BP 160 M	3GBP 168 363-***A	1465/730	85.0/71.0	0.83/0.57	11.5/9.6	6.8/4.0	36/35	2.1/2.0	2.6/2.3	0.089	127
9/4.5	M3BP 160 L	3GBP 168 364-***A	1465/730	86.5/73.5	0.83/0.56	18/16	7.0/4.1	59/59	2.1/2.1	2.7/2.5	0.119	148
14/7	M3BP 180 L	3GBP 188 356-***A	1475/735	88.0/76.0	0.83/0.56	28/24	7.7/4.2	91/91	2.6/2.3	2.9/2.3	0.225	207
18.5/9.4	M3BP 200 MLA	3GBP 208 207-***A	1475/730	89.5/82.5	0.85/0.65	35/26	7.3/4.3	120/123	2.2/1.9	2.5/1.8	0.28	255
22/11	M3BP 200 MLB	3GBP 208 208-***A	1480/735	90.5/83.0	0.84/0.60	42/32	8.4/4.7	142/143	2.6/2.4	2.9/2.2	0.34	275
28/14	M3BP 225 SMB	3GBP 228 205-***A	1480/735	90.0/85.5	0.85/0.61	53/39	7.7/4.9	181/182	2.1/2.4	2.7/2.2	0.41	330
34/17	M3BP 225 SMC	3GBP 228 206-***A	1480/735	92.0/87.0	0.86/0.66	63/43	7.9/4.8	219/221	2.2/2.2	2.7/2.0	0.49	355
50/25	M3BP 250 SMB	3GBP 258 203-***A	1480/740	92.5/88.0	0.87/0.60	90/68	8.6/6.0	323/323	2.6/3.5	3.0/2.9	0.89	465
60/30	M3BP 280 SMB	3GBP 289 222-***G	1486/741	92.8/89.5	0.86/0.65	110/74	6.8/5.4	386/387	2.0/2.7	2.6/2.3	1.5	665
74/37	M3BP 280 SMC	3GBP 289 232-***G	1487/741	94.0/90.2	0.86/0.64	132/93	7.3/5.7	475/477	2.2/2.9	2.7/2.4	1.85	725
90/45	M3BP 315 SMB	3GBP 319 222-***G	1490/742	94.3/91.0	0.84/0.64	165/112	7.3/5.0	577/579	2.0/2.4	2.8/2.1	2.6	960
110/55	M3BP 315 SMC	3GBP 319 232-***G	1490/742	94.5/91.5	0.84/0.63	200/139	7.3/5.0	705/708	2.0/2.5	2.8/2.1	2.9	1000
140/70	M3BP 315 MLA	3GBP 319 412-***G	1489/742	94.9/92.2	0.85/0.63	250/173	7.0/5.0	898/901	2.0/2.6	2.7/2.2	3.5	1160
180/90	M3BP 355 SMA	3GBP 359 212-***G	1491/743	95.4/93.5	0.84/0.62	330/225	6.8/6.0	1153/1157	1.6/2.4	2.7/2.4	5.9	1610
250/115	M3BP 355 SMC	3GBP 359 232-***G	1490/744	95.7/93.8	0.85/0.60	445/293	6.7/6.4	1602/1476	1.6/2.7	2.6/2.5	7.2	1820
330/145	M3BP 355 MLB	3GBP 359 422-***G	1492/743	96.0/94.1	0.83/0.63	605/355	7.8/6.1	2112/1864	2.1/2.5	3.1/2.3	8.4	2140

Data for other sizes on request.

The two bullets in the product code indicate choice of mounting arrangement, voltage and frequency (see ordering information page).

LV Process performance cast iron motors

Technical data for totally enclosed squirrel cage three phase motors, two-speed

IP 55 – IC 411 – Insulation class F, temperature rise class F

Output kW	Motor type	Product code	Speed r/min	Effi- ciency %	Power factor cos φ	Current		Torque			Moment of inertia J = ¼ GD ² kgm ²	Weight kg	
						I _N A	I _s I _N	T _N Nm	T _s T _N	T _{max} T _N			
1500/750 r/min = 4 - 8 poles			400 V 50 Hz			Constant torque, Dahlander-connection							
8/4.5	M3BP 160 M	3GBP 168 309-**A	1440/730	84.5/79.5	0.86/0.60	16/13,5	4.5/3.4	53/59	1.3/1.4	1.8/1.9	0.089	127	
12/7	M3BP 160 L	3GBP 168 310-**A	1445/730	86.5/81.0	0.87/0.59	23/21	5.0/3.5	79/92	1.5/1.4	1.9/1.9	0.119	148	
16/8	M3BP 180 L	3GBP 188 304-**A	1460/730	88.0/78.5	0.86/0.53	31/28	1.9/3.4	105/104	1.4/1.6	1.9/2.1	0.224	207	
22/13	M3BP 200 MLA	3GBP 208 107-**A	1475/735	87.5/86.0	0.81/0.69	45/32	6.5/5.9	142/169	2.0/2.5	2.6/2.7	0.36	245	
25/15	M3BP 200 MLB	3GBP 208 108-**A	1475/735	89.0/86.0	0.86/0.67	47/38	7.6/6.0	162/195	2.2/2.6	2.7/2.7	0.42	260	
29/17	M3BP 200 MLC	3GBP 208 109-**A	1475/735	90.0/88.0	0.91/0.75	52/38	7.2/6.1	188/221	2.2/2.6	2.4/2.4	0.48	275	
35/21	M3BP 225 SMB	3GBP 228 105-**A	1475/735	90.0/89.0	0.90/0.74	63/47	6.7/5.8	227/273	1.7/2.1	2.2/2.3	0.63	320	
42/25	M3BP 225 SMC	3GBP 228 106-**A	1475/735	91.0/89.5	0.91/0.75	74/54	6.8/5.9	272/325	1.8/2.1	2.2/2.2	0.74	345	
50/30	M3BP 250 SMB	3GBP 258 103-**A	1480/740	92.0/90.5	0.90/0.75	86/70	7.3/6.4	355/426	2.1/2.5	2.5/2.5	1.5	460	
65/40	M3BP 280 SMB	3GBP 289 229-**G	1487/743	93.2/92.2	0.88/0.69	116/92	7.8/6.6	417/514	2.0/2.7	2.8/2.7	2.2	645	
85/50	M3BP 280 SMC	3GBP 289 239-**G	1487/743	93.9/93.0	0.88/0.68	149/115	8.7/7.2	546/643	2.4/3.0	3.0/2.9	2.85	725	
95/65	M3BP 315 SMB	3GBP 319 229-**G	1489/744	94.0/93.4	0.88/0.72	166/140	7.8/6.2	609/834	2.4/2.7	2.8/2.5	4.1	930	
115/80	M3BP 315 SMC	3GBP 319 239-**G	1489/743	94.4/93.8	0.89/0.73	198/167	8.0/6.2	738/1028	2.6/2.6	2.8/2.4	4.9	1000	
150/95	M3BP 315 MLA	3GBP 319 419-**G	1489/744	94.3/94.2	0.88/0.73	260/201	8.1/6.5	962/1219	2.7/2.9	2.8/2.5	5.8	1150	
190/120	M3BP 315 LKA	3GBP 319 819-**G	1489/744	94.6/94.3	0.88/0.73	332/252	8.6/6.8	1219/1540	2.9/3.0	3.0/2.5	7.3	1410	
200/125	M3BP 355 SMB	3GBP 359 229-**G	1490/745	95.2/94.9	0.90/0.71	340/270	8.5/6.9	1282/1602	2.4/2.6	2.9/2.6	9.7	1680	
290/185	M3BP 355 MLB	3GBP 359 429-**G	1490/744	95.6/95.1	0.90/0.72	490/390	8.5/6.5	1859/2374	2.7/2.5	3.0/2.5	13.5	2180	
1000/750 r/min = 6/8 poles			400 V 50 Hz			Constant torque, two separate windings							
16/12	M3BP 200 MLB	3GBP 208 219-**A	985/740	86.5/82.5	0.85/0.73	31/29	7.0/6.3	155/155	2.1/2.4	2.4/2.6	0.42	260	
18/13.5	M3BP 200 MLC	3GBP 208 220-**A	985/740	87.5/83.5	0.83/0.72	36/32	7.9/6.6	174/174	2.5/2.6	2.8/2.8	0.48	275	
23/17	M3BP 225 SMB	3GBP 228 213-**A	985/740	89.0/85.5	0.84/0.78	46/37	7.9/6.3	222/220	2.3/2.2	2.7/2.3	0.63	320	
28/20	M3BP 225 SMC	3GBP 228 214-**A	985/740	89.0/86.5	0.86/0.77	57/43	7.1/6.5	272/259	2.0/2.3	2.4/2.4	0.74	345	
37/27	M3BP 250 SMB	3GBP 258 207-**A	990/740	90.0/87.5	0.83/0.75	71/59	7.8/6.7	357/348	2.3/2.5	2.7/2.5	1.41	460	
47/35	M3BP 280 SMB	3GBP 289 226-**G	991/744	92.2/90.7	0.83/0.69	89/81	6.5/7.1	453/449	2.1/3.3	2.5/2.5	2.2	645	
60/45	M3BP 280 SMC	3GBP 289 236-**G	992/743	93.2/91.7	0.83/0.71	112/100	7.4/7.1	578/578	2.4/3.3	2.7/2.4	2.85	725	
75/56	M3BP 315 SMB	3GBP 319 226-**G	993/744	92.8/92.5	0.82/0.74	142/118	7.3/6.7	721/719	1.8/2.6	2.7/2.6	4.1	930	
88/66	M3BP 315 SMC	3GBP 319 236-**G	993/744	93.2/93.0	0.83/0.74	165/139	7.3/7.0	846/847	1.8/2.8	2.7/2.7	4.9	1000	
106/80	M3BP 315 MLA	3GBP 319 416-**G	993/744	93.6/93.3	0.83/0.73	198/171	7.5/7.5	1019/1026	1.9/3.1	2.7/2.8	5.8	1150	
110/83	M3BP 355 SMA	3GBP 359 216-**G	994/746	94.9/93.7	0.82/0.72	204/177	7.3/8.0	1057/1062	1.9/3.0	2.6/2.7	7.9	1520	
135/100	M3BP 355 SMB	3GBP 359 226-**G	994/745	95.1/94.0	0.82/0.75	250/204	7.3/7.2	1297/1282	2.0/2.7	2.6/2.4	9.7	1680	
155/116	M3BP 355 SMC	3GBP 359 236-**G	994/744	95.3/94.2	0.82/0.75	288/236	7.1/7.1	1489/1489	1.9/2.7	2.5/2.4	11.3	1820	
180/135	M3BP 355 MLB	3GBP 359 426-**G	994/744	95.1/94.3	0.81/0.74	340/282	6.8/7.1	1729/1733	2.0/2.9	2.5/2.5	13.5	2180	
220/165	M3BP 355 LKB	3GBP 359 826-**G	993/744	95.3/94.4	0.81/0.74	410/340	6.2/6.9	2116/2118	1.8/2.8	2.2/2.4	16.5	2600	

Data for other sizes on request.

The two bullets in the product code indicate choice of mounting arrangement, voltage and frequency (see ordering information page).

LV Process performance cast iron motors - Variant codes

Code	Variant	Motor size				
		71-132	160-180	200-250	280-315	355-400
Balancing						
052	Balancing to Grade A (IEC 60034-14).	S	S	S	S	S
417	Balancing to Grade B (IEC 60034-14).	P	P	P	P	P
423	Balanced without key	NA	P	P	P	P
424	Full key balancing.	M	P	P	P	P
Bearings and lubrication						
036	Transport lock for bearings.	NA	M	M	M	M
037	Roller bearing at D-end.	NA	M	M	M	M
039	Cold resistant grease. For bearing temperatures, sizes 71-132 -30...+ 120°C, sizes 160-250 -40...+ 100°C, sizes 280-400 -55...+ 100°C.	M	M	M	M	M
040	Heat resistant grease. For bearing temperatures -25 - +150°C.	M	S	S	M	M
041	Bearings regreasable via grease nipples.	NA	S	S	S	S
042	Locked drive-end.	S	S	S	S	S
043	SPM nipples. Frame sizes 112-132 only foot-mounted B3.	M	S	S	S	S
057	2RS bearings at both ends. Grease for bearing temperatures -20 - +110°C.	S	M	M	NA	NA
058	Angular contact ball bearing at D-end, shaft force away from bearing.	NA	M	M	P	P
059	Angular contact ball bearing at N-end, shaft force towards bearing.	NA	R	R	P	P
060	Angular contact bearing at D-end, shaft force towards bearing.	NA	NA	NA	P	P
061	Angular contact bearing at N-end, shaft force away from bearing.	NA	NA	NA	P	P
107	Bearing mounted PT100 resistance elements.	NA	P	P	M	M
194	2Z-bearings greased for life at both ends.	NA	M	M	NA	NA
420	Bearing mounted PTC thermistors.	NA	R	R	M	M
433	Grease relief.	NA	S	S	P	P
796	Grease nipples JIS B 1575 PT 1/8 Type A.	NA	M	M	M	M
797	Stainless steel SPM nipples.	NA	M	M	M	M
798	Stainless steel grease nipples.	NA	M	M	M	M
Brakes ²⁾						
412	Built-on brake.	NA	P	P	P	P
Branch standard designs						
142	"Manilla" winding connection. (440 VΔ series, 220 VΔ parallel, 60 Hz).	NA	P	P	P	P
415	Smoke venting design (short time duty in high ambient temperature).	NA	NA	NA	R	R
170	Smoke venting specification 200°C, 2 hours.	NA	R	R	R	R
171	Smoke venting specification 300°C, 0.5 hour.	NA	R	R	R	R
172	Smoke venting specification 300°C, 1 hour.	NA	R	R	R	R
173	Smoke Venting specification, 200°C, 2 hours, according to pe EN 12101-3	NA	R	R	R	R
174	Smoke Venting specification, 400°C, 2 hours, according to pe EN 12101-3	NA	R	R	R	R
175	Smoke Venting specification, 250°C, 2 hours, according to pe EN 12101-3	NA	R	R	R	R
178	Stainless steel/acid proof bolts.	M	M	M	M	M
209	Non-standard voltage or frequency (special winding).	M	P	P	P	P
396	Motor designed for ambient -20°C to -40°C, with heating. (code 450/451 must be added)	NA	P	P	P	P
397	Motor designed for ambient -40°C to -55°C, with heating. (code 450/451 must be added)	NA	R	R	P	P
398	Motor designed for ambient -20°C to -40°C, without heating.	NA	P	P	P	P
399	Motor designed for ambient -40°C to -55°C, without heating.	NA	R	R	P	P

¹⁾ Certain variant codes cannot be used simultaneously.

²⁾ More information available in the Accessories section

S = Included as standard

M = On modification of a stocked motor,
or on new manufacture,
the number per order may be limited.

P = New manufacture only.

R = On request.

NA = Not applicable

Code 1)	Variant	Motor size				
		71-132	160-180	200-250	280-315	355-400
416	High speed design.	NA	R	R	P	P
419	Textile industry design.	M	R	M	R	R
425	Corrosion protected stator and rotor core.	S	P	P	P	P
785	Reinforced tropicalisation.	S	P	P	S	S
Cooling system						
044	Unidirectional fan, clockwise seen from D-end.	NA	NA	NA	P	P
045	Unidirectional fan, counter clockwise seen from D-end.	NA	NA	NA	P	P
054	Special fan for noise reduction.	NA	NA	NA	R	R
068	Metal fan. Mandatory for ambient temperatures $\geq 60^{\circ}\text{C}$.	M	M	M	M	M
075	Cooling method IC 418 (without fan). Output on request.	M	R	R	P	P
183	Separate motor cooling (fan axial, N-end).	M	M	M	P	P
422	Separate motor cooling (fan top or side, N-end).	NA	NA	NA	P	P
790	Cast iron fan cover.	NA	NA	NA	P	NA
791	Stainless steel fan cover.	NA	R	R	P	P
793	Fan for reduced noise level (2 poles fan)	NA	R	R	M	M
794	Fan for reduced noise level (4 poles fan)	NA	R	R	P	P
Coupling						
035	Assembly of customer supplied coupling-half (finish bored and balanced).	R	R	R	P	P
Dimension drawing						
141	Binding dimension drawing.	M	M	M	M	M
Drain holes						
065	Plugged existing drain holes.	NA	M	M	M	M
066	Modified drain hole position (for specified IM xxxx).	M	M	M	M	M
076	Draining holes with plugs. Felt plugs.	M	NA	NA	S	S
448	Draining holes with metal plugs.	M	NA	NA	R	R
Earthing bolt						
067	External earthing bolt.	M	S	S	S	S
Hazardous environments						
See catalogue "Motors for Hazardous Environments", BU/Ex-motors GB", for details.						
449	Ex n design, according to Australian Standard AS 2380.9	M	NA	NA	NA	NA
456	Ex nA design, fulfilling IEC 79-15, with certificate.	M	NA	NA	NA	NA
480	EEx nA, fulfilling EN 50021.	M	NA	NA	M	NA
Heating elements						
450	Heating element, 100-120 V.	M	M	M	M	M
451	Heating element, 200-240 V.	M	M	M	M	M
Insulation system						
014	Winding insulation class H.	P	P	P	P	P
405	Special winding insulation for frequency converter supply, rated supply > 500 V.	NA	P	P	P	P
406	Winding for supply > 690 \leq 1000 V.	NA	P	P	P	P
Marine Motors						
See catalogue "Marine Motors, BU/Marine GB" for details.						

1) Certain variant codes cannot be used simultaneously.

S = Included as standard

M = On modification of a stocked motor, or on new manufacture, the number per order may be limited.

P = New manufacture only.

R = On request.

NA = Not applicable

Code 1)	Variant	Motor size				
		71-132	160-180	200-250	280-315	355-400
Mounting arrangements						
008	IM 2101 foot/flange mounted, IEC flange, from IM 1001 (B34 from B3).	M	NA	NA	NA	NA
009	IM 2001 foot/flange mounted, IEC flange, from IM 1001 (B35 from B3).	M	M	M	M	M
047	IM 3601 flange mounted, IEC flange, from IM 3001 (B14 from B5).	M	R/NA	NA	NA	NA
048	IM 3001 flange mounted, IEC flange, from IM 3601 (B5 from B14).	M	NA	NA	NA	NA
078	IM 3601 flange mounted, DIN C flange. Sizes 71-112	M	NA	NA	NA	NA
090	IM 2101 foot/flange mounted, DIN C flange, from IM 1001 (B34 from B3). Sizes 71-112.	M	NA	NA	NA	NA
304	PAD mounting according to BS4999-141	NA	P	P	M	M
305	Additional lifting lugs for V1, V3, V5, V6, V15 and V36	NA	P	P	S	S
Noise reduction						
055	Noise reducing cover	NA	NA	NA	P	P
Painting						
114	Special paint colour, standard grade.	M	M	M	M	M
111	Offshore two-pack polyamide cured epoxy paint 160 mm	NA	R	R	P	P
115	Offshore zink primer painting.	NA	R	R	P	P
179	Special paint specification.	R	R	R	R	R
Protection						
072	Radial seal at D-end.	M	M	M	M	M
073	Sealed against oil at D-end.	P	M	M	R	R
211	Weather protected, IP xxW.	M	M	M	R	R
005	Protective roof, vertical motor, shaft down. ²⁾	M	M	M	M	M
401	Protective roof, horizontal motor.	M	NA	NA	P	P
158	Degree of protection IP 65.	M	M	M	M	M
403	Degree of protection IP 56.	M	M	M	M	M
404	Degree of protection IP 56, without fan and fan cover.	NA	P	P	P	P
783	Labyrinth sealing at D-end.	NA	R	R	M	S
784	Gamma-seal at D-end.	S	S	S	R	NA
Rating & instruction plates						
002	Restamping voltage, frequency and output, continuous duty.	M	M	M	M	M
003	Individual serial number.	M	S	S	S	S
013	Restamping to output for class F temperature rise. Applies to variants with temperature rise to class B as standard.	M	R	R	M	M
095	Restamping output (maintained voltage, frequency), intermittent duty.	M	M	M	M	M
098	Stainless rating plate.	S	S	S	S	S
135	Mounting of additional identification plate, stainless.	M	M	M	M	M
138	Mounting of additional identification plate, aluminum.	M	NA	NA	NA	NA
139	Additional identification plate delivered loose.	M	M	M	M	M
150	Instruction plates and maintenance instructions in non-standard language.	R	NA	NA	R	R
160	Additional rating plate affixed.	M	M	M	M	M
161	Additional rating plate delivered loose.	M	M	M	M	M
163	Additional frequency converter rating plate fixed to stator	NA	M	M	M	M

¹⁾ Certain variant codes cannot be used simultaneously.

²⁾ More information available in the Accessories section

S = Included as standard

M = On modification of a stocked motor,
or on new manufacture,
the number per order may be limited.

P = New manufacture only.

R = On request.

NA = Not applicable

Code	Variant	Motor size				
		71-132	160-180	200-250	280-315	355-400
Shaft & rotor						
069	Two shaft extensions as per basic catalogue. Standard shaft material.	NA	P	P	P	P
070	One or two special shaft extensions, standard shaft material.	R	R	R	P	P
155	Cylindrical shaft extension, D-end, without key-way.	NA	NA	NA	P	P
156	Cylindrical shaft extension, N-end, without key-way.	NA	NA	NA	P	P
164	Shaft extension with closed key-way.	R	S	S	P	P
165	Shaft extension with open key-way.	S	P	P	S	S
410	Stainless/acid-proof steel shaft (standard or non-standard design).	NA	R	R	P	P
427	Shaft extension complies with Australian Standards (AS).	R	NA	NA	P	P
431	Special shaft material for low temperatures, -40°C.	R	R	R	P	P
Standards and regulations						
010	Fulfilling CSA Safety Certificate.	NA	M	M	M	M
011	Fulfilling CSA Energy Efficiency Verification (code 010 included).	NA	R	R	P	P
421	VIK-design (Verband der Industriellen Energie- und Kraftwirtschaft e.V.).	M	M	M	M	M
773	EEMUA No 132 1988 design.	NA	R	R	R	R
774	Design according to NORSOK (North Sea Territorial Waters).	P	R	R	P	P
775	Design according to SHELL DEP 33.66.05.31 -Gen. January 1999 design.	P	P	P	P	P
778	GOST R Export/Import Certificate (Russia)	NA	M	M	M	M
779	SASO Export/Import Certificate (Saudi Arabia)	M	M	M	M	M
787	UIC Design (Union of Chemical Industries)	P	P	P	NA	NA
Stator winding temperature sensors						
Breaking capacity for bimetal detector:						
<u>Sizes 71-100:</u>		<u>Sizes 112-250</u>		<u>Sizes 280-400</u>		
2 A at 380 V ac		4 A at 250 V ac		24 A at 250 V		
5 A at 240 V ac		3 A at 60 V dc				
2.5 A at 24 V dc						
121	Bimetal detectors, break type (NCC), (3 in series), 130°C, in stator winding.	M	M	M	M	M
122	Bimetal detectors, break type (NCC), (3 in series), 150°C, in stator winding.	M	M	M	M	M
123	Bimetal detectors, break type (NCC), (3 in series), 170°C, in stator winding.	M	M	M	M	M
124	Bimetal detectors, break type (NCC), (2x3 in series), 140°C, in stator winding.	NA	M	M	R	R
125	Bimetal detectors, break type (NCC), (2x3 in series), 150°C, in stator winding.	M	M	M	M	M
127	Bimetal detectors, break type (NCC), (3 in series, 130°C and 3 in series, 150°C), in stator winding.	M	M	M	M	M
435	PTC - thermistors (3 in series), 130°C, in stator winding. Two speed motors, only for new manufacture.	M	M	M	M	M
436	PTC - thermistors (3 in series), 150°C, in stator winding. Two speed motors, only for new manufacture.	S	S	S	S	S
437	PTC - thermistors (3 in series), 170°C, in stator winding. Two speed motors, only for new manufacture.	M	M	M	M	M
439	PTC - thermistors (2x3 in series), 150°C, in stator winding. Two speed motors, only for new manufacture.	M	M	M	M	M
441	PTC - thermistors (3 in series, 130°C and 3 in series, 150°C, in stator winding. Two speed motors, only for new manufacture.	M	M	M	M	M
442	PTC - thermistors (3 in series, 150°C and 3 in series, 170°C, in stator winding. Two speed motors, only for new manufacture.	M	M	M	M	M
445	PT100 (1 per phase) in stator winding. Not possible for size 71.	M	M	M	M	M
446	PT100 (2 per phase) in stator winding. Not possible for sizes 71-90.	M	M	M	M	M

¹⁾ Certain variant codes cannot be used simultaneously.

S = Included as standard
M = On modification of a stocked motor, or on new manufacture, the number per order may be limited.

P = New manufacture only.
R = On request.
NA = Not applicable

Code	Variant	Motor size				
		71-132	160-180	200-250	280-315	355-400
Terminal box						
015	Motor supplied in Δ -connection.	M	M	M	M	M
017	Motor supplied in Y-connection.	M	M	M	M	M
019	Larger than standard terminal box.	NA	NA	NA	P	R
021	Terminal box LHS (seen from D-end). For size 71 not possible.	P	P	P	P	P
022	Cable entry LHS (seen from D-end).	NA	M	M	M	M
180	Terminal box RHS (seen from D-end). For size 71 not possible.	P	P	P	P	P
137	Extended cable connection, low terminal box, "Flying leads".	R	NA	NA	P	P
157	Terminal box degree of protection IP 65.	M	M	M	P	P
230	Standard cable glands.	M	M	M	S	S
231	Standard cable glands with clamping device.	M	R	R	M	M
400	4 x 90 degr turnable terminal box.	S	S	S	S	S
402	Terminal box adapted for Al cables.	NA	NA	NA	S	S
409	Large terminal box with two terminal blocks.	NA	NA	NA	P	R
413	Extended cable connection, no terminal box.	NA	NA	NA	P	P
414	Smaller than standard terminal box.	NA	NA	NA	R	R
418	Separate terminal box for temperature detectors.	M	M	M	P	P
447	Top mounted separate terminal box for monitoring equipment.	R	R	R	M	M
466	Terminal box at N-end.	R	R	R	P	P
467	Lower than standard terminal box and rubber extended cable. Cable length 2 m, included.	P	P	P	R	R
468	Cable entry from D-end.	M	R	R	M	M
469	Cable entry from N-end.	M	M	M	M	M
729	Cable flanges without holes / Blank gland plates.	NA	M	M	M	M
731	Two standard cable glands.	M	M	M	S	S
739	Prepared for metric cable glands according to DIN 42925, draft aug. 1999.	NA	M	M	M	M
740	Prepared for PG cable glands.	NA	M	M	M	M
743	Painted steel flange for cable glands.	NA	M	M	M	M
744	Stainless steel flange for cable glands.	NA	M	M	M	M
745	Painted steel flange equipped with brass cable glands.	NA	R	R	M	M
Testing						
140	Test confirmation.	M	M	M	NA	NA
145	Type test report from test of identical motor.	M	M	M	M	M
146	Type test with report for motor from specific delivery batch.	R	M	M	M	M
147	Type test with report for motor from specific delivery batch, customer witnessed.	R	M	M	M	M
148	Routine test report.	M	M	M	M	M
149	Testing according to separate test specification.	R	R	R	M	M
153	Reduced test for classification society.	R	M	M	NA	NA
221	Type test and multi-point load test with report for motor from specific delivery batch.	R	M	M	M	M
222	Torque/speed curve, type test and multi-point load test with report for motor from specific delivery batch.	NA	M	M	M	M
760	Vibration level test.	M	M	M	M	M
761	Vibration spectrum test.	NA	R	R	R	R
762	Noise level test.	NA	M	M	M	M
763	Noise spectrum test.	NA	R	R	R	R
764	Complete test with ABB frequency converter, available at ABB test field.	R	R	R	R	R
Variable speed drives						
701	Insulated bearing at N-end	NA	R	M	M	M
704	EMC cable termination	NA	M	M	M	M
Separate motor cooling						
183	Separate motor cooling (fan axial, N-end). ²⁾	P	M	M	P	P
189	Separate motor cooling, IP44, 400V, 50Hz (fan axial, N-end). ²⁾	NA	M	M	NA	NA

¹⁾ Certain variant codes cannot be used simultaneously.

²⁾ More information available in the Accessories section

S = Included as standard

M = On modification of a stocked motor,
or on new manufacture,
the number per order may be limited.

P = New manufacture only.

R = On request.

NA = Not applicable

Code ¹⁾	Variant	Motor size				
		71-132	160-180	200-250	280-315	355-400
422	Separate motor cooling (fan top or side, N-end).	NA	NA	NA	P	P
Mounting of tachometer; tachometer not included						
182	Pulse sensor mounted as specified (Leine & Linde equivalent, hollow-shaft type).	NA	R	R	P	P
470	Prepared for hollow shaft pulse tachometer (Leine&Linde equivalent).	NA	M	M	M	M
479	Mounting of other types of tachometers with shaft extension.	NA	R	R	P	P
570	Prepared for hollow shaft pulse tachometer (L&L 562).	NA	M	M	R	R
Mounting of tachometer; tachometer included						
062	Tachogenerator.	R	NA	NA	P	P
471	512 hollow shaft pulse tachometer (Leine&Linde equivalent) mounted.	NA	R	R	P	P
472	1024 hollow shaft pulse tachometer (Leine&Linde equivalent) mounted. ²⁾	NA	M	M	M	M
473	2048 hollow shaft pulse tachometer (Leine&Linde equivalent) mounted. ²⁾	NA	M	M	M	M
572	1024 pulse tachometer (L&L 562). ²⁾	NA	M	M	R	R
573	2048 pulse tachometer (L&L 562). ²⁾	NA	M	M	R	R
748	Pulse tachometer Lake Shore (RIM 8500) mounted.	NA	R	R	P	P
749	Pulse tachometer Avtron (M285) mounted.	NA	R	R	P	P
Separate motor cooling & prepared for tachometer; tachometer not included						
474	Separate motor cooling and prepared for hollow shaft pulse tachometer (Leine&Linde equivalent). ²⁾	NA	M	M	M	M
478	Separate motor cooling (fan top, N-end) and prepared for hollow shaft pulse tachometer (Leine&Linde equivalent).	NA	NA	NA	P	P
574	Separate motor cooling (fan axial, N-end) and prepared for hollow shaft tachometer (L&L 562)	NA	M	M	R	R
578	Separate motor cooling, IP 44, 400 V, 50 Hz (fan axial, N-end) and prepared for hollow shaft tachometer (L&L 562)	NA	M	M	R	R
486	Separate motor cooling (fan top, N-end) and prepared for DC tachometer.	NA	NA	NA	P	P
487	Separate motor cooling (fan axial, N-end) and prepared for hollow shaft pulse tachometer (Lake Shore RIM 8500 or Avtron M285).	NA	R	R	P	P
Separate motor cooling & tachometer; tachometer included						
428	Separate motor cooling (fan top, N-end) and Leine & Linde, type 510 006361, pulse tachometer.	NA	NA	NA	P	P
429	Separate motor cooling (fan top, N-end) and Leine & Linde, type 861007455, hollow shaft pulse tachometer.	NA	NA	NA	P	P
430	Separate motor cooling (fan top, N-end) and DC tachometer, shaft extension type.	NA	NA	NA	P	P
475	Separate motor cooling (fan axial, N-end) and 512 hollow shaft pulse tachometer (L&L equivalent).	NA	R	R	P	P
476	Separate motor cooling (fan axial, N-end) and 1024 hollow shaft pulse tachometer (L&L equivalent). ²⁾	NA	M	M	P	P
477	Separate motor cooling (fan axial, N-end) and 2048 hollow shaft pulse tachometer (L&L equivalent). ²⁾	NA	M	M	P	P
488	Separate motor cooling (fan axial, N-end) and Lake Shore RIM 8500 pulse tachometer mounted.	NA	R	R	P	P
489	Separate motor cooling (fan axial, N-end) and Avtron M285 pulse tachometer mounted.	NA	R	R	P	P
576	Separate motor cooling (fan axial, N-end) and 1024 pulse tachometer (L&L 562). ²⁾	NA	M	M	R	R
577	Separate motor cooling (fan axial, N-end) and 2048 pulse tachometer (L&L 562). ²⁾	NA	M	M	R	R
580	Separate motor cooling, IP44, 400V, 50Hz (fan axial, N-end) and 1024 pulse tachometer (L&L 562).	NA	M	M	R	R
581	Separate motor cooling, IP44, 400V, 50Hz (fan axial, N-end) and 2048 pulse tachometer (L&L 562).	NA	M	M	R	R
Y/Δ-starting						
117	Terminals for Y/Δ start at both speeds (two speed windings).	NA	P	P	P	R
118	Terminals for Y/Δ start at high speed (two speed windings).	NA	NA	NA	P	R
119	Terminals for Y/Δ start at low speed (two speed windings).	NA	R	R	P	R

¹⁾ Certain variant codes cannot be used simultaneously.

²⁾ More information available in the Accessories section

S = Included as standard

M = On modification of a stocked motor, or on new manufacture, the number per order may be limited.

P = New manufacture only.

R = On request.

NA = Not applicable

LV Process performance cast iron motors Sizes 71-132

Dimension drawings

Foot-mounted: IM B3 (IM 1001), IM B6 (IM 1051), IM B7 (IM 1061), IM B8 (IM 1071),
IM V5 (IM 1011), IM V6 (IM 1031)

Terminal box top-mounted

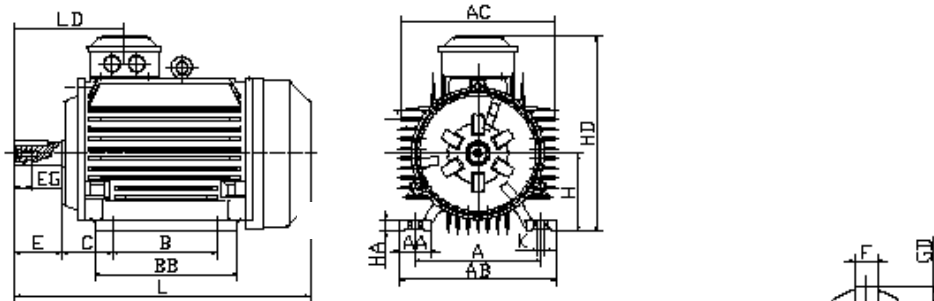

Terminal box on right hand side

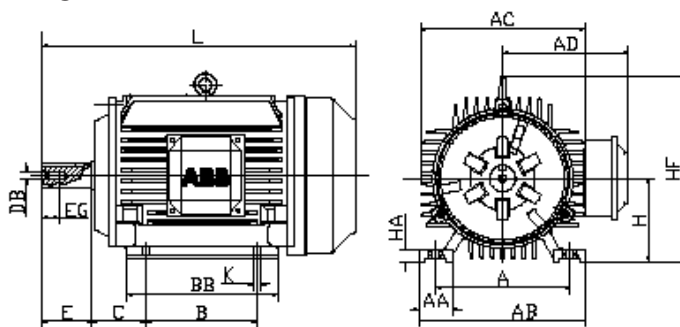

Motor size	Poles	A	AA	AB	AC	AD	B	BB	C	D	DB	E	EG
71	2-6	112	30	145	145	120	90	110	45	14	M5	30	12.5
80	2-6	125	35	160	165	145	100	135	50	19	M6	40	16
90 S	2-6	140	35	175	180	150	100	140	56	24	M8	50	19
90 L	2-6	140	35	175	180	150	125	165	56	24	M8	50	19
100	2-6	160	40	200	205	175	140	180	63	28	M10	60	22
112	2-8	190	50	235	225	185	140	190	70	28	M10	60	22
132 S	2-8	216	55	270	265	205	140	205	89	38	M12	80	28
132 M	2-8	216	55	270	265	205	178	240	89	38	M12	80	28

Motor size	Poles	F	G	GD	H	HA	HD	HF	K	L	LD
71	2-6	5	11	5	71	10	190	-	7	255	100
80	2-6	6	15.5	6	80	12	225	170	10	285	116
90 S	2-6	8	20	7	90	12	240	185	10	310	128
90 L	2-6	8	20	7	90	12	240	185	10	335	128
100	2-6	8	24	7	100	14	275	245	12	380	144
112	2-6	8	24	7	100	15	290	265	12	380	144
132 S	2-6	10	33	8	132	18	335	300	12	465	169
132 M	2-6	10	33	8	132	18	335	300	12	505	169

Tolerances:

A, B	± 0,8	F	ISO h9
C	± 0.8	H	+0 -0.5
D	ISO j6	N	ISO j6

Above table gives the main dimensions in mm.

For detailed drawings please see our web-pages 'www.abb.com/motors&drives' or contact us.

LV Process performance cast iron motors Sizes 71-132

Dimension drawings

Flange-mounted; IM B5 (IM 3001), V1 (IM 3011), V3 (IM 3031) and IM B14 (IM 3601), V18 (IM 3611), V19 (IM 3631)

Large flange (B5)

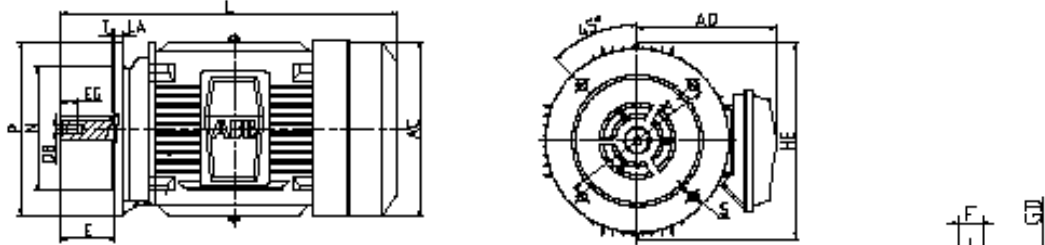

Small flange (B14)

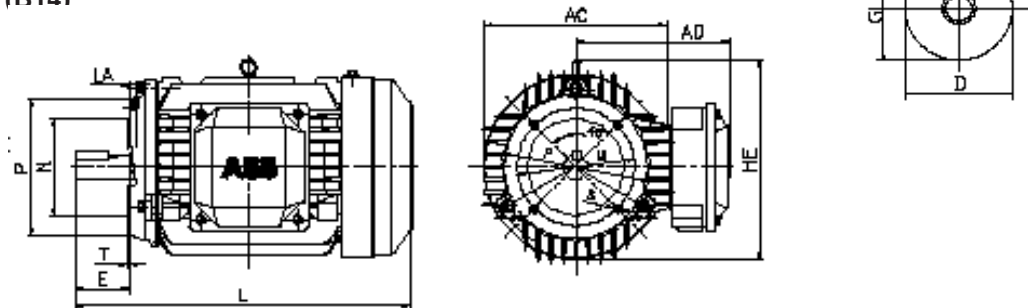

IM B5 (IM 3001), IM V1 (IM 3011), IM V3 (IM 3031)

Motor size	Poles	AC	AD	D	DB	E	EG	F	G	GD	HE	L	LA	M	N	P	S	T
71	2-6	145	120	14	M5	30	12.5	5	11	5	165	255	9	130	110	160	10	3.5
80	2-8	165	145	19	M6	40	16	6	15.5	6	200	285	9	165	130	200	12	3.5
90 S	2-8	180	150	24	M8	50	19	8	20	7	200	310	10	165	130	200	12	3.5
90 L	2-8	180	150	24	M8	50	19	8	20	7	200	335	10	165	130	200	12	3.5
100	2-8	205	175	28	M10	60	22	8	24	7	265	380	11	215	180	250	15	4
112	2-8	225	185	28	M10	60	22	8	24	7	270	395	11	215	180	250	15	4
132 S	2-8	265	205	38	M12	80	28	10	33	8	320	465	12	265	230	300	15	4
132 M	2-8	265	205	38	M12	80	28	10	33	8	320	505	12	265	230	300	15	4

IM B14 (IM 3601), IM V18 (IM 3611), IM V19 (IM 3631)

Motor size	Pole	Flange size	HE	P	M	N	S	T
71	2-6	C105	145	105	85	70	M6	2.5
		C140	145	140	115	95	M8	3
80	2-8	C120	165	120	100	80	M6	3
		C160	165	160	130	110	M8	3.5
90 S	2-8	C140	185	140	115	95	M8	3
		C160	185	160	130	110	M8	3.5
90 L	2-8	C140	185	140	115	95	M8	3
		C160	185	160	130	110	M8	3.5
100	2-8	C160	255	160	130	110	M8	3.5
		C200	255	200	165	130	M10	3.5
112	2-8	C160	265	160	130	110	M8	3.5
		C200	265	200	165	130	M10	3.5

Tolerances:

D, DA ISO m6
F, FA ISO h9
N ISO j6

Above table gives the main dimensions in mm.

For detailed drawings please see our web-pages 'www.abb.com/motors&drives' or contact us.

LV Process performance cast iron motors

Sizes 71-132

Dimension drawings

Foot- and flange-mounted: IM B35 (IM 2001), IM V15 (IM 2011), IM V36 (IM 2031)

Terminal box top-mounted

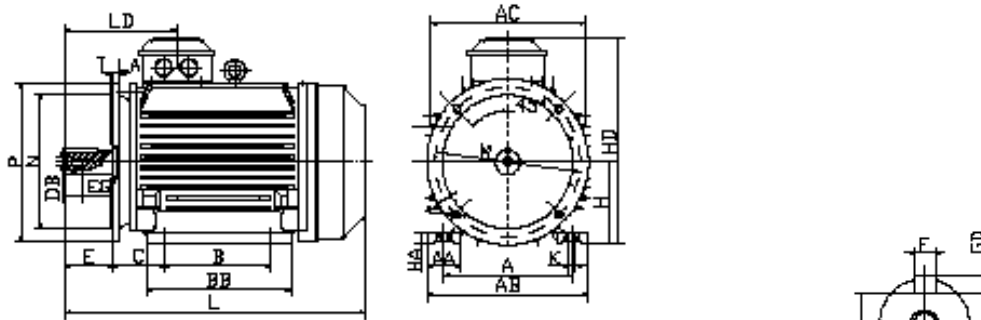

Terminal box on right hand side

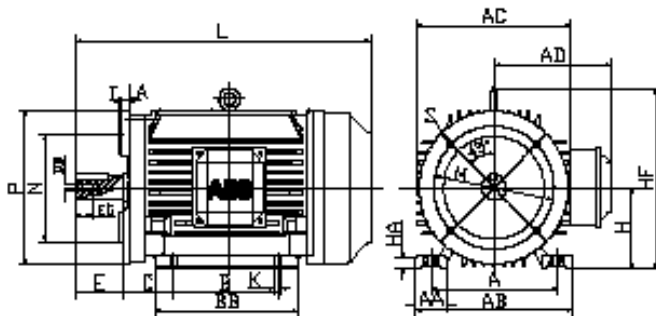

Motor size	Poles	A	AA	AB	AC	AD	B	BB	C	D	DB	E	EG	F
71	2-6	112	30	145	145	120	90	110	45	14	M5	30	12.5	5
80	2-8	125	35	160	165	145	100	135	50	19	M6	40	16	6
90 S	2-8	140	35	175	180	150	100	140	56	24	M8	50	19	8
90 L	2-8	140	35	175	180	150	125	165	56	24	M8	50	19	8
100	2-8	160	40	200	205	175	140	180	63	28	M10	60	22	8
112	2-8	190	50	235	225	185	140	190	70	28	M10	60	22	8
132 S	2-8	216	55	270	265	205	140	205	89	38	M12	80	28	10
132 M	2-8	216	55	270	265	205	178	240	89	38	M12	80	28	10

Motor size	Poles	G	GD	H	HA	HD	HF	K	L	LA	LD	M	N	P	S	T
71	2-6	11	5	71	10	200	-	7	255	9	100	130	110	160	10	3.5
80	2-8	15.5	6	80	12	225	170	10	285	9	116	165	130	200	12	3.5
90 S	2-8	20	7	90	12	240	185	10	310	10	128	165	130	200	12	3.5
90 L	2-8	20	7	90	12	240	185	10	335	10	128	165	130	200	12	3.5
100	2-8	24	7	100	14	275	245	12	380	11	138	215	180	250	15	4
112	2-8	24	7	112	15	290	265	12	395	11	144	215	180	250	15	4
132 S	2-8	33	8	132	18	335	300	12	465	12	169	265	230	300	15	4
132 M	4-8	33	8	132	18	335	300	12	505	12	169	265	230	300	15	4

Tolerances:

A, B	± 0,8	H	+0 -0.5
D	ISO j6 (size 71)	N	ISO j6
	ISO k6 (sizes 80-112)	C	± 0.8
F	ISO h9		

Above table gives the main dimensions in mm.

For detailed drawings please see our web-pages 'www.abb.com/motors&drives' or contact us.

LV Process performance cast iron motors Sizes 160-250

Dimension drawings

Foot-mounted: IM B3 (IM 1001), IM B6 (IM 1051), IM B7 (IM 1061), IM B8 (IM 1071),
IM V5 (IM 1011), IM V6 (IM 1031)

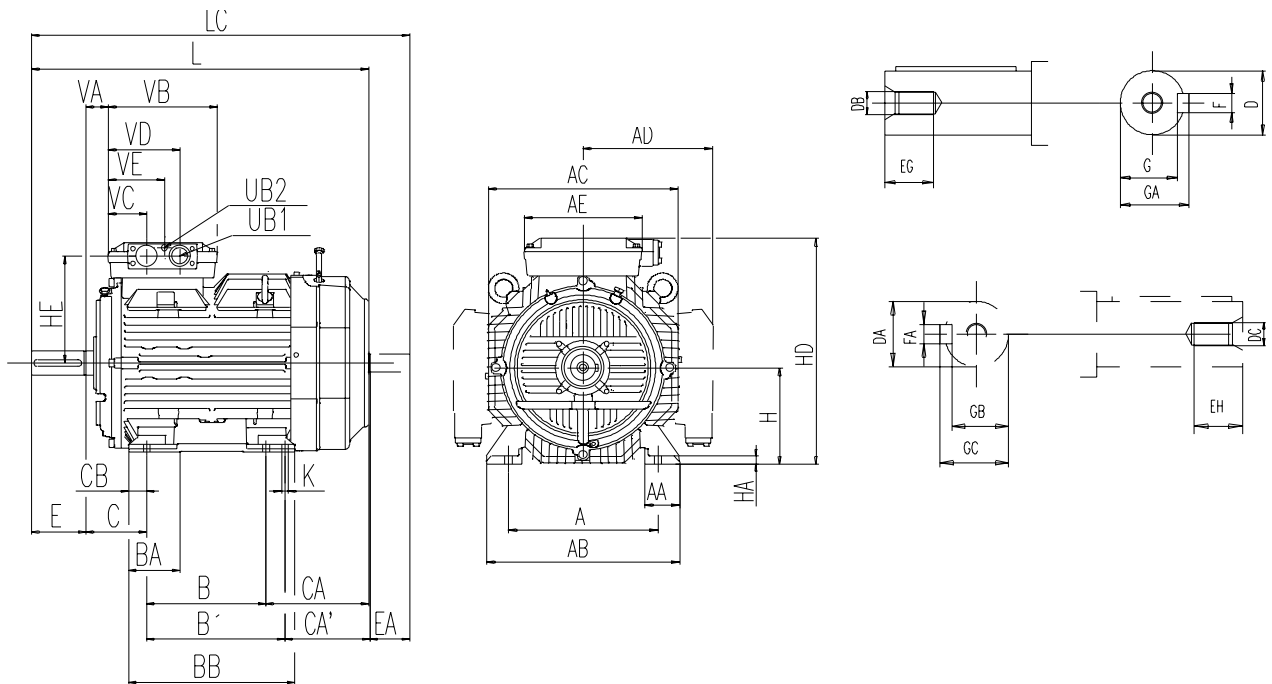

Motor size	Poles	A	AA	AB	AC	AD	AE	B	B'	BA	BB	C	CA	CA'	CB	D	DA	DB	DC	E	EA	EG	EH	F	FA
160 ¹⁾	2-8	254	60	320	316	202	220	210	254	104	299	108	185.5	141.5	17	42	32	M16	M12	110	80	36	28	12	10
160L ²⁾	2-8	254	60	320	316	202	220	210	254	104	299	108	226.5	182.5	17	42	32	M16	M12	110	80	36	28	12	10
180 ³⁾	2-8	279	65	360	356	242	220	241	279	103	335	121	249	180	35	48	32	M16	M12	110	80	36	28	14	10
180L ⁴⁾	2-8	279	65	360	356	242	220	241	279	103	335	121	238	200	35	48	32	M16	M12	110	80	36	28	14	10
200ML	2-8	318	65	390	390	306	312	267	305	111	378	133	273	235	37	55	45	M20	M16	110	110	42	36	16	14
225SM	2	356	74	432	430	326	312	286	311	112	393	149	330	305	30	55	55	M20	M20	110	110	42	42	16	16
225SM	4-8	356	74	432	430	326	312	286	311	112	393	149	270	245	30	60	55	M20	M20	140	110	42	42	18	16
250SM	2	406	81	480	480	334	312	311	349	105	441	168	263	225	69	60	55	M20	M20	140	110	42	42	18	16
250SM	4-8	406	81	480	480	334	312	311	349	105	441	168	263	225	69	65	55	M20	M20	140	110	42	42	18	16

Motor size	Poles	G	GA	GB	GC	H	HA	HD	HE	K	L	LC	UB1	UB2	VA	VB	VC	VD	VE
160 ¹⁾	2-8	37	45	27	35	160	17	382	195	14.5	602.5	693.5	M40	M16	56	220	76.5	143.5	110
160L ²⁾	2-8	37	45	27	35	160	17	382	195	14.5	643.5	734.5	M40	M16	56	220	76.5	143.5	110
180 ³⁾	2-8	42.5	51.5	27	35	180	16	422	215	14.5	680	770	M40	M16	43.5	220	76.5	143.5	110
180L ⁴⁾	2-8	42.5	51.5	27	35	180	16	422	215	14.5	700.5	790	M40	M16	43.5	220	76.5	143.5	110
200ML	2-8	49	59	39.5	48.5	200	22	506	255	18.5	774	893	M63	M16	35.5	310	110	200	155
225SM	2	49	59	49	59	225	22	552	275	18.5	836	985	M63	M16	53.5	310	110	200	155
225SM	4-8	53	64	49	59	225	22	552	275	18.5	866	955	M63	M16	53.5	310	110	200	155
250SM	2	53	64	49	59	250	26	605	283	24	845	992	M63	M16	53	310	110	200	155
250SM	4-8	58	69	49	59	250	26	605	283	24	875	992	M63	M16	53	310	110	200	155

Tolerances:

A, B	± 0,8	F, FA	ISO h9
C, CA	± 0,8	H	+0 -0,5
D, DA	ISO k6 < Ø 50mm		
	ISO m6 > Ø 50mm		

¹⁾ MA2, M2, L2, LB2, M4, L4, LB4, M6, L6, MA8, M8, MA2/4, M2/4, L2/4, M4/6, M4/8

²⁾ LB6, L8, LB8, L4/6, L4/8

³⁾ M2, LB2, M4, L6, L8, M2/4, M4/6, M4/8

⁴⁾ L4, LB4, LB6, LB8, L2/4, L4/6, L4/8

Above table gives the main dimensions in mm.

For detailed drawings please see our web-pages
'www.abb.com/motors&drives' or contact us.

LV Process performance cast iron motors Sizes 160-250

Dimension drawings

Flange-mounted; IM B5 (IM 3001) , V1 (IM 3011), V3 (IM 3031) and IM B14 (IM 3601), V18 (IM 3611), V19 (IM 3631)

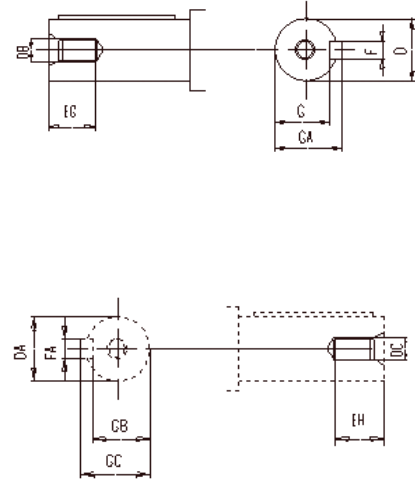
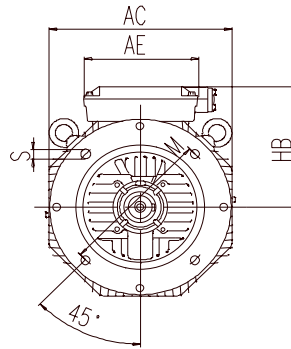
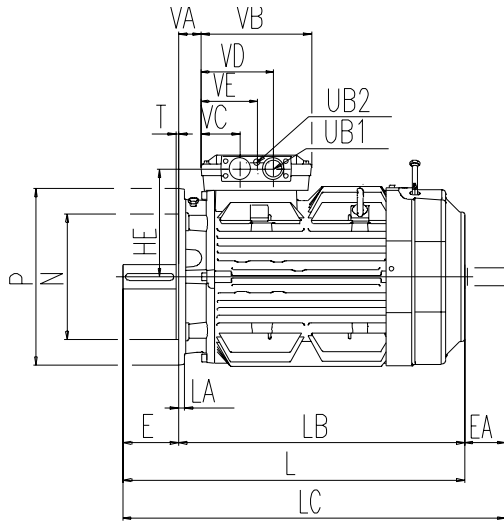

2

Motor size	Poles	AC	AE	D	DA	DB	DC	E	EA	EG	EH	F	FA	G	GA	GB	GC	HB	HE	L
160 ¹⁾	2-8	316	220	42	32	M16	M12	110	80	36	28	12	10	37	45	27	35	202	195	602,5
160L ²⁾	2-8	316	220	42	32	M16	M12	110	80	36	28	12	10	37	45	27	35	202	195	643,5
180 ³⁾	2-8	356	220	48	32	M16	M12	110	80	36	28	14	10	42,5	51,5	27	35	242	215	680
180L ⁴⁾	2-8	356	220	48	32	M16	M12	110	80	36	28	14	10	42,5	51,5	27	35	242	215	700,5
200ML	2-8	390	312	55	45	M20	M16	110	110	42	36	16	14	49	59	39,5	48,5	306	255	774
225SM	2	430	312	55	55	M20	M20	110	110	42	42	16	16	49	59	49	59	327	275	836
225SM	4-8	430	312	60	55	M20	M20	140	110	42	42	18	16	53	64	49	59	327	275	866
250SM	2	480	312	60	55	M20	M20	140	110	42	42	18	16	53	64	49	59	355	283	875
250SM	4-8	480	312	65	55	M20	M20	140	110	42	42	18	16	58	69	49	59	355	283	875

Motor size	Poles	LA	LB	LC	M	N	P	S	T	UB1	UB2	VA	VB	VC	VD	VE
160 ¹⁾	2-8	18	492,5	693,5	300	250	350	19	5	M40	M16	56	220	76,5	143,5	110
160L ²⁾	2-8	18	533,5	734,5	300	250	350	19	5	M40	M16	56	220	76,5	143,5	110
180 ³⁾	2-8	20	570	770	300	250	350	19	5	M40	M16	43,5	220	76,5	143,5	110
180L ⁴⁾	2-8	20	590,5	790	300	250	350	19	5	M40	M16	43,5	220	76,5	143,5	110
200ML	2-8	19,5	664	893	350	300	400	19	5	M63	M16	35,5	310	110	200	155
225SM	2	21	726	985	400	350	450	19	5	M63	M16	53,5	310	110	200	155
225SM	4-8	21	726	955	400	350	450	19	5	M63	M16	53,5	310	110	200	155
250SM	2	25	735	992	500	450	550	19	5	M63	M16	53,5	310	110	200	155
250SM	4-8	25	735	992	500	450	550	19	5	M63	M16	53,5	310	110	200	155

Tolerances:

D, DA ISO k6 < Ø 50mm
 ISO m6 > Ø 50mm
 F, FA ISO h9
 N ISO j6

- ¹⁾ MA2, M2, L2, LB2, M4, L4, LB4, M6, L6, MA8, M8, MA2/4, M2/4, L2/4, M4/6, M4/8
- ²⁾ LB6, L8, LB8, L4/6, L4/8
- ³⁾ M2, LB2, M4, L6, L8, M2/4, M4/6, M4/8
- ⁴⁾ L4, LB4, LB6, LB8, L2/4, L4/6, L4/8

Above table gives the main dimensions in mm.
 For detailed drawings please see our web-pages 'www.abb.com/motors&drives' or contact us.

LV Process performance cast iron motors Sizes 160-250

Dimension drawings

Foot- and flange-mounted: IM B35 (IM 2001), IM V15 (IM 2011), IM V36 (IM 2031)

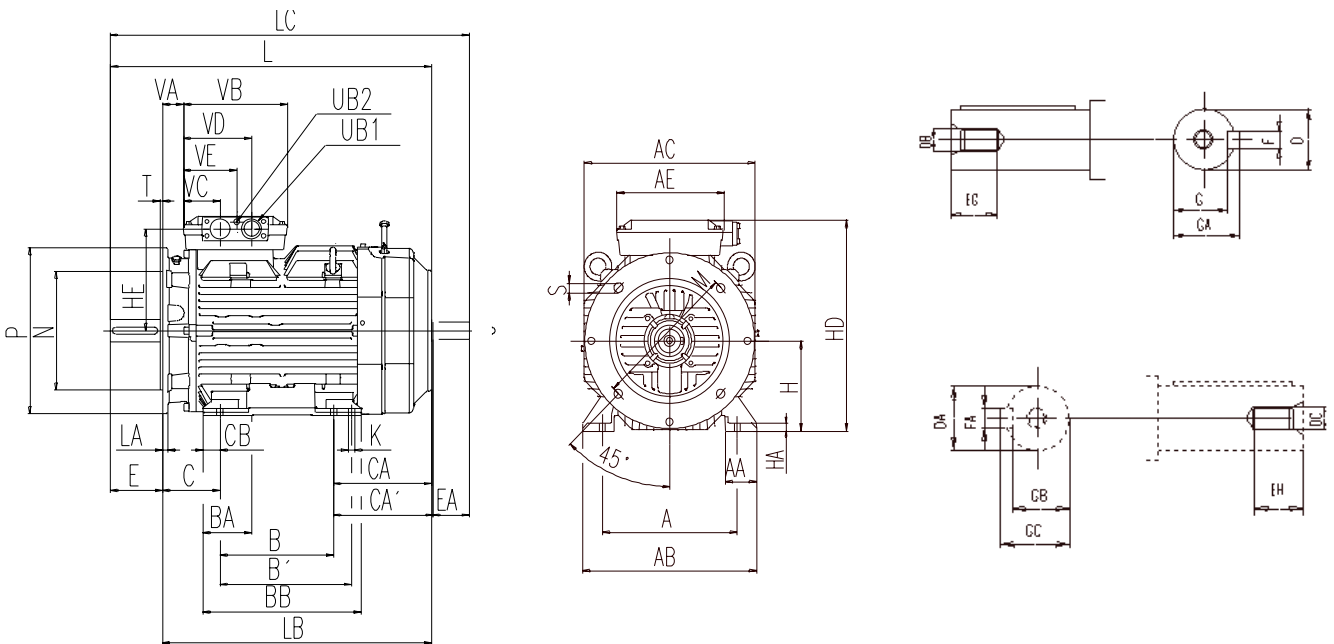

Motor size	Poles	A	AA	AB	AC	AE	B	B'	BA	BB	C	CA	CA'	CB	D	DA	DB	DC	E	EA	EG	EH	F	FA	G	GA
160 ₁	2-8	254	60	320	316	220	210	254	104	299	108	185.5	141.5	17	42	32	M16	M12	110	80	36	28	12	10	37	45
160L ₂	2-8	254	60	320	316	220	210	254	104	299	108	226.5	182.5	17	42	32	M16	M12	110	80	36	28	12	10	37	45
180 ₃	2-8	279	65	360	356	220	241	279	103	335	121	249	180	35	48	32	M16	M12	110	80	36	28	14	10	42.5	51.5
180L ₄	2-8	279	65	360	356	220	241	279	103	335	121	238	200	35	48	32	M16	M12	110	80	36	28	14	10	42.5	51.5
200ML	2-8	318	65	390	390	312	267	305	111	378	133	273	235	37	55	45	M20	M16	110	110	42	36	16	14	49	59
225SM	2	356	74	432	430	312	286	311	112	393	149	330	305	30	55	55	M20	M20	110	110	42	42	16	16	49	59
225SM	4-8	356	74	432	430	312	286	311	112	393	149	270	245	30	60	55	M20	M20	140	110	42	42	18	16	53	64
250SM	2	406	81	480	480	312	311	349	105	441	168	263	225	69	60	55	M20	M20	140	110	42	42	18	16	53	64
250SM	4-8	406	81	480	480	312	311	349	105	441	168	263	225	69	65	55	M20	M20	140	110	42	42	18	16	58	69

Motor size	Poles	GB	GC	H	HA	HD	HE	K	L	LA	LB	LC	M	N	P	S	T	UB1	UB2	VA	VB	VC	VD	VE
160 ₁	2-8	27	35	160	17	382	195	14.5	602.5	18	492.5	694	300	250	350	19	5	M40	M16	56	220	76.5	143.5	110
160L ₂	2-8	27	35	160	17	382	195	14.5	643.5	18	533.5	735	300	250	350	19	5	M40	M16	56	220	76.5	143.5	110
180 ₃	2-8	27	35	180	16	422	215	14.5	680	20	570	770	300	250	350	19	5	M40	M16	43.5	220	76.5	143.5	110
180L ₄	2-8	27	35	180	16	422	215	14.5	700.5	20	590.5	790	300	250	350	19	5	M40	M16	43.5	220	76.5	143.5	110
200ML	2-8	39.5	48.5	200	22	506	255	18.5	774	19.5	664	893	350	300	400	19	5	M63	M16	35.5	310	110	200	155
225SM	2	49	59	225	22	552	275	18.5	836	21	726	985	400	350	450	19	5	M63	M16	53.5	310	110	200	155
225SM	4-8	49	59	225	22	552	275	18.5	866	21	726	955	400	350	450	19	5	M63	M16	53.5	310	110	200	155
250SM	2	49	59	250	26	605	283	24	845	25	735	992	500	450	550	19	5	M63	M16	53	310	110	200	155
250SM	4-8	49	59	250	26	605	283	24	875	25	735	992	500	450	550	19	5	M63	M16	53	310	110	200	155

Tolerances:

A, B	± 0,8	F, FA	ISO h9
C, CA	± 0,8	H	+0 -0,5
D, DA	ISO k6 < Ø 50 mm ISO m6 > Ø 50 mm	N	ISO j6

- 1) MA2, M2, L2, LB2, M4, L4, LB4, M6, L6, MA8, M8, MA2/4, M2/4, L2/4, M4/6, M4/8
- 2) LB6, L8, LB8, L4/6, L4/8
- 3) M2, LB2, M4, L6, L8, M2/4, M4/6, M4/8
- 4) L4, LB4, LB6, LB8, L2/4, L4/6, L4/8

Above table gives the main dimensions in mm.

For detailed drawings please see our web-pages 'www.abb.com/motors&drives' or contact us.

LV Process performance cast iron motors Sizes 280-315

Dimension drawings

Foot-mounted: IM B3 (IM 1001), IM B6 (IM 1051), IM B7 (IM 1061), IM B8 (IM 1071), IM V5 (IM 1011), IM V6 (IM 1031)

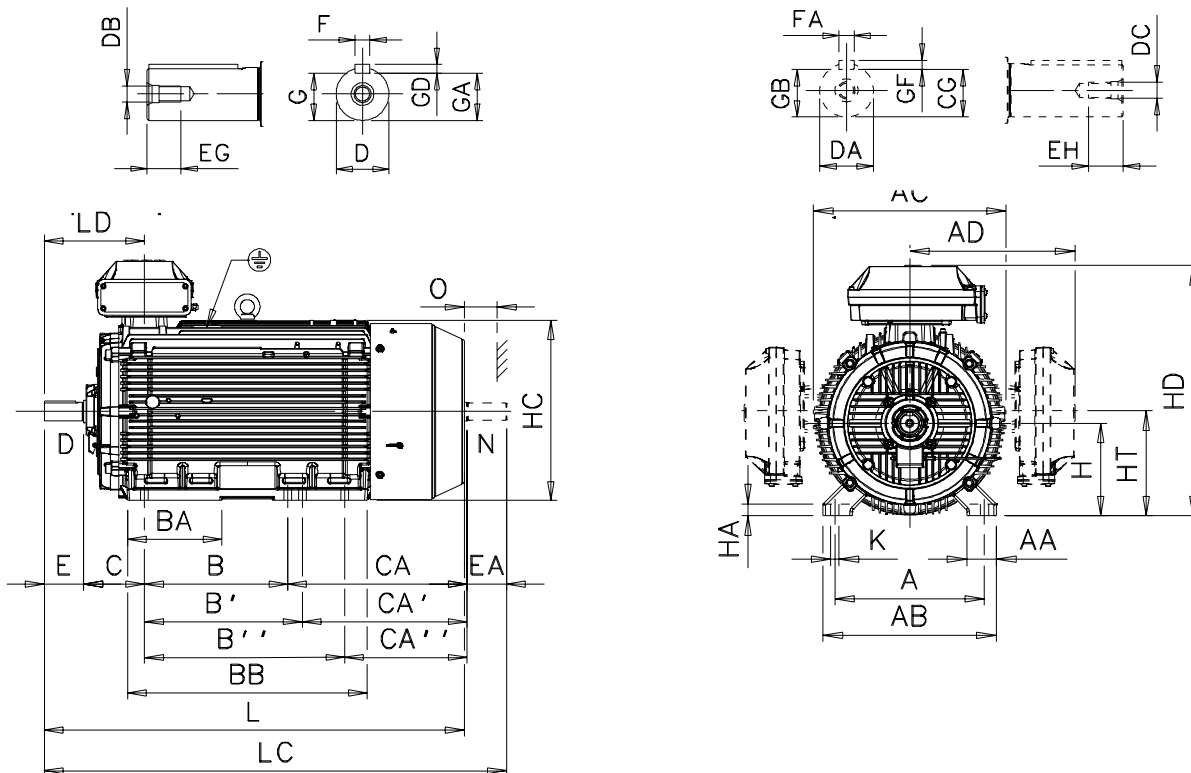

Motor size	Poles	A	AA	AB	AC	AD ¹⁾	AD ²⁾	B	B'	B''	BA	BB	C	CA	CA'	CA''	D	DA	DB	DC	E	EA	EGEH	
280 SM_	2	457	84	530	577	481	-	368	419	-	147	506	190	400	349	-	65	60	M20	M20	140	140	40	40
	4-12	457	84	530	577	481	-	368	419	-	147	506	190	400	349	-	75	65	M20	M20	140	140	40	40
315 SM_	2	508	100	590	654	545	-	406	457	-	180	558	216	422	371	-	65	60	M20	M20	140	140	40	40
	4-12	508	100	590	654	545	-	406	457	-	180	558	216	422	371	-	80	75	M20	M20	170	140	40	40
315 ML_	2	508	100	590	654	545	-	457	508	-	212	669	216	482	431	-	65	60	M20	M20	140	140	40	40
	4-12	508	100	590	654	545	-	457	508	-	212	669	216	482	431	-	90	75	M24	M20	170	140	48	40
315 LK_	2	508	100	590	654	562	576	508	560	710	336	851	216	637	585	435	65	60	M20	M20	140	140	40	40
	4-12	508	100	590	654	562	576	508	560	710	336	851	216	637	585	435	90	75	M24	M20	170	140	48	40

Motor size	Poles	F	FA	G	GA	GB	GC	GD	GF	H	HA	HC	HD ¹⁾	HD ²⁾	HT	K	L	LC	LD	LD	O
													top-m.	top-m.				top-m.	side-m.		
280 SM_	2	18	18	58	69	53	64	11	11	280	31	564	762	-	337.5	24	1088	1238	336	539	100
	4-12	20	18	67.5	79.5	58	69	12	11	280	31	564	762	-	337.5	24	1088	1238	336	539	100
315 SM_	2	18	18	58	69	53	64	11	11	315	40	639	852	-	375	28	1174	1324	356	585	115
	4-12	22	20	71	85	67.5	79.5	14	12	315	40	639	852	-	375	28	1204	1354	386	615	115
315 ML_	2	18	18	58	69	53	64	11	11	315	40	639	852	-	375	28	1285	1435	356	640	115
	4-12	25	20	81	95	67.5	79.5	14	12	315	40	639	852	-	375	28	1315	1465	386	670	115
315 LK_	2	18	18	58	69	53	64	11	11	315	40	639	870	880	359	28	1491	1641	356	721	115
	4-12	25	20	81	95	67.5	79.5	14	12	315	40	639	852	880	359	28	1521	1671	386	751	115

Tolerances:

A, B	± 0,8	F	ISO h9
C, CA	± 0.8	H	+0 -0.5
D	ISO k6 < Ø 50mm ISO m6 > Ø 50mm	N	ISO j6

¹⁾ Terminal box 370

²⁾ Terminal box 750

Above table gives the main dimensions in mm.

For detailed drawings please see our web-pages www.abb.com/motors&drives or contact us.

LV Process performance cast iron motors Sizes 280-315

Dimension drawings

Flange-mounted; IM B5 (IM3001), V1 (IM3011), V3 (IM3031) and IM B14 (IM3601), V18 (IM3611), V19 (IM3631)

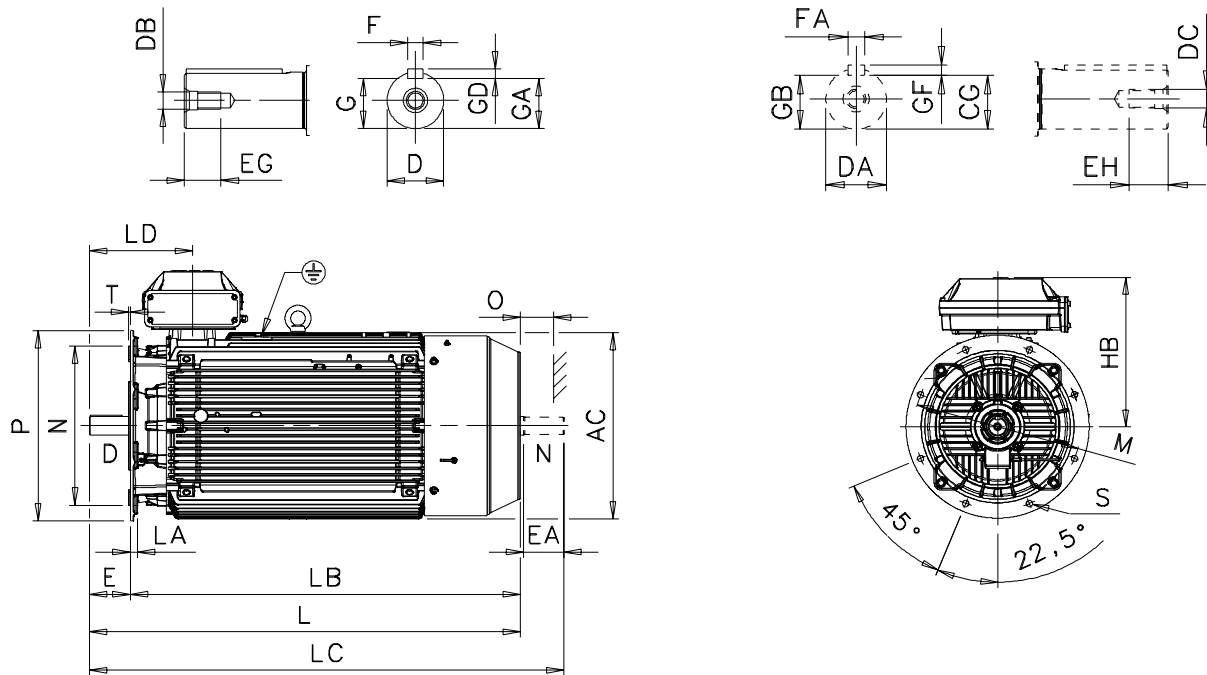

2

Motor size	Poles	AC	D	DA	DB	DC	E	EA	EG	EH	F	FA	G	GA	GB	GC	GD	GF
280 SM_	2	577	65	60	M20	M20	140	140	40	40	18	18	58	69	53	64	11	11
	4-12	577	75	65	M20	M20	140	140	40	40	20	18	67.5	79.5	58	69	12	11
315 SM_	2	645	65	60	M20	M20	140	140	40	40	18	18	58	69	53	64	11	11
	4-12	645	80	75	M20	M20	170	140	40	40	22	20	71	85	67.5	79.5	14	12
315 ML_	2	645	65	60	M20	M20	140	140	40	40	18	18	58	69	53	64	11	11
	4-12	645	90	75	M24	M20	170	140	48	40	25	20	81	95	67.5	79.5	14	12
315 LK_	2	645	65	60	M20	M20	140	140	40	40	18	18	58	69	53	64	11	11
	4-12	645	90	75	M24	M20	170	140	48	40	25	20	81	95	67.5	79.5	14	12

Motor size	Poles	HB ¹⁾	HB ²⁾	L	LA	LB	LC	LD	M	N	O	P	S	T
280 SM_	2	482	-	1088	23	948	1238	336	500	450	100	550	18	5
	4-12	482	-	1088	23	948	1238	336	500	450	100	550	18	5
315 SM_	2	537	-	1174	25	1034	1324	356	600	550	115	660	23	6
	4-12	537	-	1204	25	1034	1354	386	600	550	115	660	23	6
315 ML_	2	537	-	1285	25	1145	1435	356	600	550	115	660	23	6
	4-12	537	-	1315	25	1145	1465	386	600	550	115	660	23	6
315 LK_	2	537	585	1491	25	1306	1641	356	600	550	115	660	23	6
	4-12	537	585	1521	25	1306	1671	386	600	550	115	660	23	6

Tolerances:

D, DA	ISO m6	N	ISO j6 (280 SM_)
F, FA	ISO h9		ISO js6 (315_)

¹⁾ Terminal box 370

²⁾ Terminal box 750

Above table gives the main dimensions in mm.

For detailed drawings please see our web-pages 'www.abb.com/motors&drives' or contact us.

LV Process performance cast iron motors Sizes 280-315

Dimension drawings

Foot- and flange-mounted: IM B35 (IM 2001), IM V15 (IM 2011), IM V36 (IM 2031)

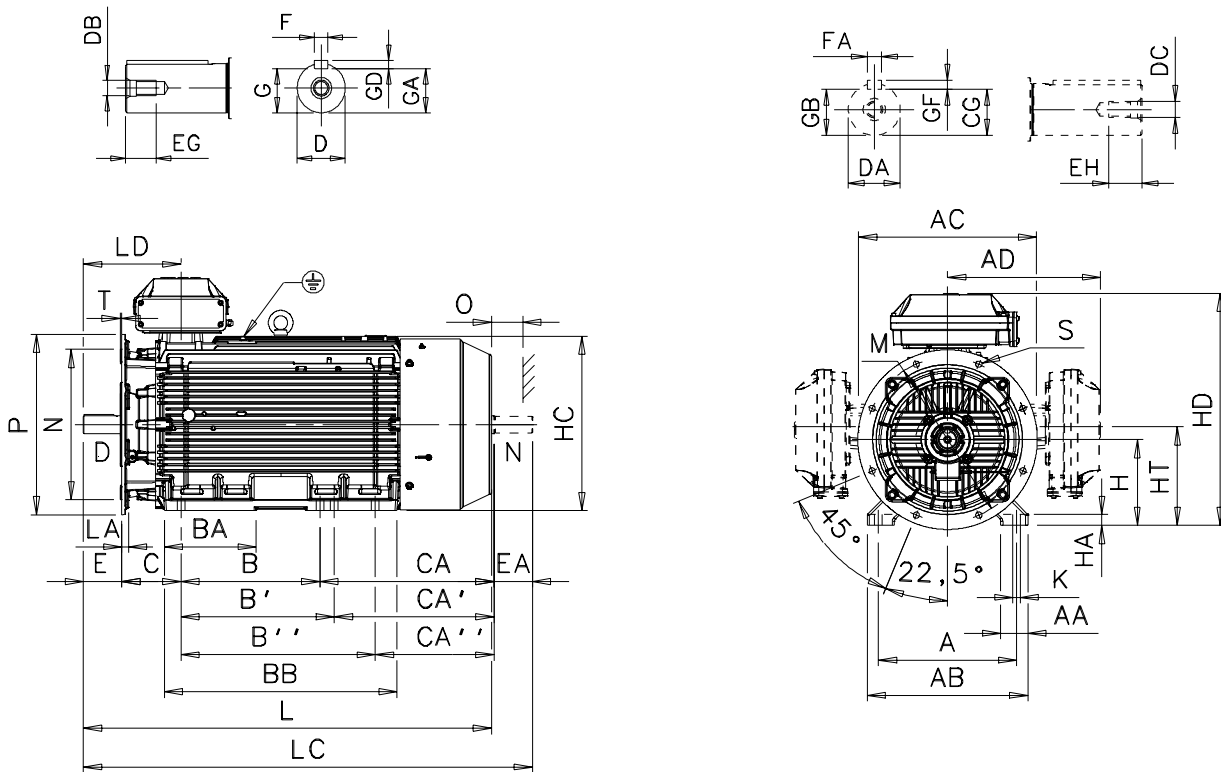

2

Motor size	Poles	A	AA	AB	AC	AD ¹⁾	AD ²⁾	B	B'	B''	BA	BB	C	CA	CA'	CA''	D	DA	DB	DC	E	EA	EG	EH	F	FA	G
280 SM_2	4-12	457	84	530	577	481	-	368	419	-	147	506	190	400	349	-	65	60	M20	M20	140	140	40	40	18	18	58
	4-12	457	84	530	577	481	-	368	419	-	147	506	190	400	349	-	75	65	M20	M20	140	140	40	40	20	18	67.5
315 SM_2	4-12	508	100	590	654	545	-	406	457	-	180	558	216	422	371	-	65	60	M20	M20	140	140	40	40	18	18	58
	4-12	508	100	590	654	545	-	406	457	-	180	558	216	422	371	-	80	75	M20	M20	170	140	40	40	22	20	71
315 ML_2	4-12	508	100	590	654	545	-	457	508	-	212	669	216	482	431	-	65	60	M20	M20	140	140	40	40	18	18	58
	4-12	508	100	590	654	545	-	457	508	-	212	669	216	482	431	-	90	75	M24	M20	170	140	48	40	25	20	81
315 LK_2	4-12	508	100	590	654	562	576	508	560	710	336	851	216	637	585	435	65	60	M20	M20	140	140	40	40	18	18	58
	4-12	508	100	590	654	562	576	508	560	710	336	851	216	637	585	435	90	75	M24	M20	170	140	48	40	25	20	81

Motor size	Poles	GA	GB	GC	GD	GF	H	HA	HC	HD ¹⁾	HD ²⁾	HT	K	L	LA	LC	LD	LD	M	N	P	S	T	O
										top-m.	top-m.						top-m.	side-m.						
280 SM_2	4-12	69	53	64	11	11	280	31	564	762	-	340	24	1088	23	1238	336	539	500	450	550	18	5	100
	4-12	79.5	58	69	12	11	280	31	564	762	-	340	24	1088	23	1238	336	539	500	450	550	18	5	100
315 SM_2	4-12	69	53	64	11	11	315	40	639	852	-	375	28	1174	25	1324	356	585	600	550	660	23	6	115
	4-12	85	67.5	79.5	14	12	315	40	639	852	-	375	28	1204	25	1354	386	615	600	550	660	23	6	115
315 ML_2	4-12	69	53	64	11	11	315	40	639	852	-	375	28	1285	25	1435	356	640	600	550	660	23	6	115
	4-12	95	67.5	79.5	14	12	315	40	639	852	-	375	28	1315	25	1465	386	670	600	550	660	23	6	115
315 LK_2	4-12	69	53	64	11	11	315	40	639	852	880	359	28	1491	25	1641	356	721	600	550	660	23	6	115
	4-12	95	67.5	79.5	14	12	315	40	639	852	880	359	28	1521	25	1671	386	751	600	550	660	23	6	115

Tolerances:

A, B	± 0,8	N	ISO j6 (280 SM_)
D	ISO m6	C	ISO js6 (315_)
F	ISO h9		± 0.8
H	+0 -1.0		

¹⁾ Terminal box 370

²⁾ Terminal box 750

Above table gives the main dimensions in mm.

For detailed drawings please see our web-pages 'www.abb.com/motors&drives' or contact us.

LV Process performance cast iron motors Sizes 355-400

Dimension drawings

Foot-mounted: IM B3 (IM 1001), IM B6 (IM 1051), IM B7 (IM 1061), IM B8 (IM 1071), IM V5 (IM 1011), IM V6 (IM 1031)

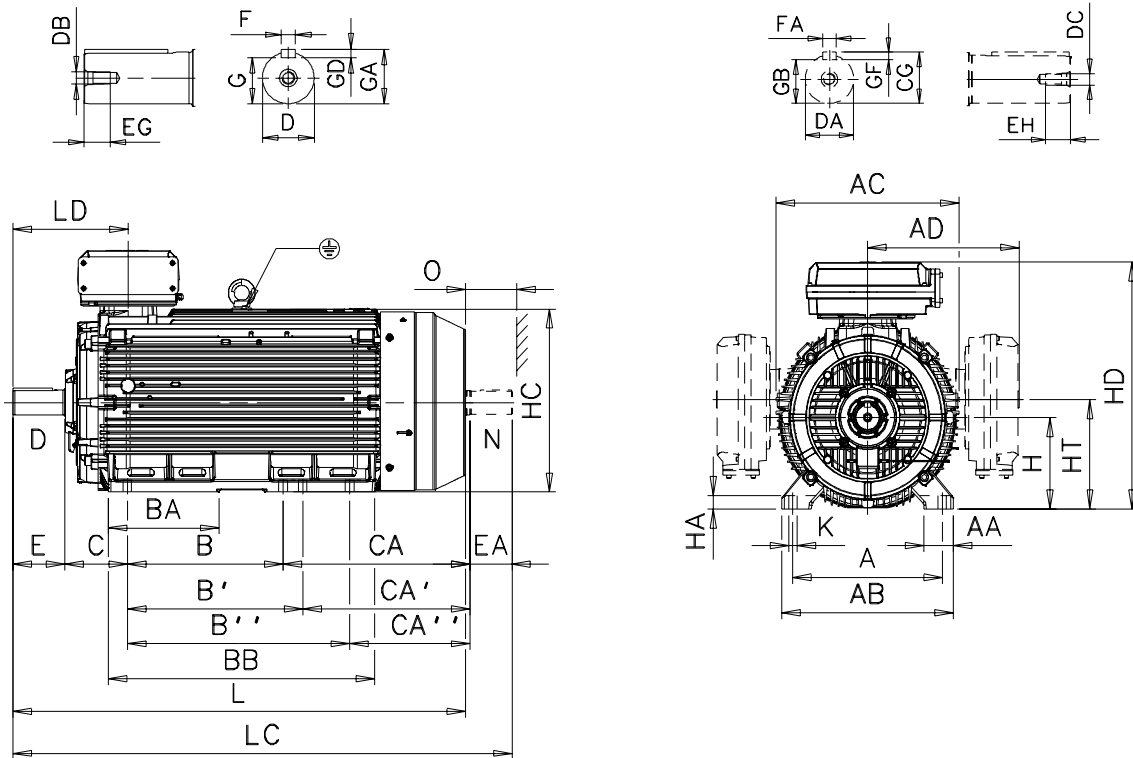

2

Motor size	Poles	A	AA	AB	AC	AD ¹⁾	AD ²⁾	B	B'	B''	BA	BB	C	CA	CA'	CA''	D	DA	DB	DC	E	EA	EG	EH
355 SM_	2	610	120	700	746	604	618	500	560	-	221	722	254	525	465	-	70	70	M20	M20	140	140	42	40
	4-12	610	120	700	746	604	618	500	560	-	221	722	254	525	465	-	100	90	M24	M24	210	170	51	48
355 ML_	2	610	120	700	746	604	618	560	630	-	267	827	254	500	570	-	70	70	M20	M20	140	140	42	40
	4-12	610	120	700	746	604	618	560	630	-	267	827	254	500	570	-	100	90	M24	M24	210	170	51	48
355 LK ³⁾	2	610	120	700	746	604	618	630	710	900	447	1077	254	750	670	480	70	70	M20	M20	140	140	42	40
	4-12	610	120	700	746	604	618	630	710	900	447	1077	254	750	670	480	100	90	M24	M24	210	170	51	48
400 L_	2	710	150	840	834	-	660	900	1000	-	410	1156	224	701	611	511	80	70	M20	M20	170	140	42	40
	4-12	710	150	840	834	-	660	900	1000	-	410	1156	224	701	611	511	110	90	M24	M24	210	170	50	48
400 LK ³⁾	2	686	150	840	834	-	660	710	800	900	410	1156	280	701	611	511	80	70	M20	M20	170	140	42	40
	4-12	686	150	840	834	-	660	710	800	900	410	1156	280	701	611	511	100	90	M24	M24	210	170	50	48

Motor size	Poles	F	FA	G	GA	GB	GC	GD	GF	H	HA	HC	HD ¹⁾	HD ²⁾	HD	K	L	LC	LD	LD	O
													top-m.	top-m.	side-m.				top-m.	side-m.	
355 SM_	2	20	20	62.5	74.5	62.5	74.5	12	12	355	52	725	944	958	843	35	1409	1559	397	679	130
	4-12	28	25	90	106	81	95	16	14	355	52	725	944	958	843	35	1479	1659	467	750	130
355 ML_	2	20	20	62.5	74.5	62.5	74.5	12	12	355	52	725	944	958	843	35	1514	1664	397	732	130
	4-12	28	25	90	106	81	95	16	14	355	52	725	944	958	843	35	1584	1764	467	802	130
355 LK ³⁾	2	20	20	62.5	74.5	62.5	74.5	12	12	355	52	725	944	958	843	35	1764	1914	397	857	130
	4-12	28	25	90	106	81	95	16	14	355	52	725	944	958	843	35	1834	2014	467	927	130
400 L_	2	22	20	71	85	67.5	79.5	12	12	400	45	773	-	1045	943	35	1851	2001	458	909	150
	4-12	28	25	90	126	81	95	16	14	400	45	773	-	1045	943	35	1891	2071	498	949	150
400 LK ³⁾	2	22	20	71	85	67.5	79.5	14	12	400	45	812	-	1045	943	35	1851	2001	458	909	150
	4-12	28	25	100	106	81	95	16	14	400	45	812	-	1045	943	35	1891	2071	498	949	150

¹⁾ Terminal box 370 ²⁾ Terminal box 750
³⁾ Size with alternative dimensions

Tolerances:

A, B ± 0,8	H +0 -1.0
D, DA ISO m6	N ISO j6
F, FA ISO h9	C, CA ± 0.8

Above table gives the main dimensions in mm.
 For detailed drawings please see our web-pages
 'www.abb.com/motors&drives' or contact us.

LV Process performance cast iron motors Sizes 355-400

Dimension drawings

Flange-mounted; IM B5 (IM 3001) , IM V1 (IM 3011), IM V3 (IM 3031), IM B14 (IM 3601), IM V18 (IM 3611) and IM V19 (IM 3631)

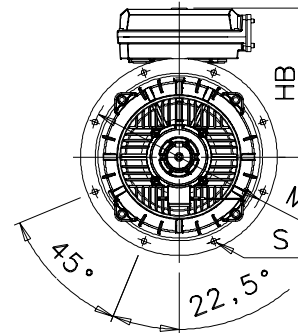
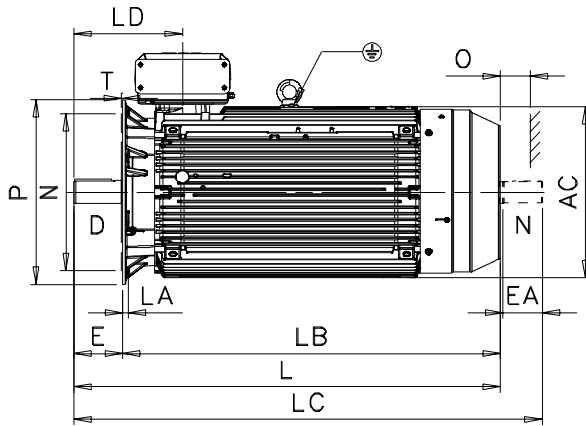

2

Motor size	Poles	AC	D	DA	DB	DC	E	EA	EG	EH	F	FA	G	GA	GB	GC	GD	GF
355 SM ₋	2	725	70	70	M20	M20	140	140	42	40	20	20	62.5	74.5	62.5	74.5	12	12
	4-12	725	100	90	M24	M24	210	170	51	48	28	25	90	106	81	95	16	14
355 ML ₋	2	725	70	70	M20	M20	140	140	42	40	20	20	62.5	74.5	62.5	74.5	12	12
	4-12	725	100	90	M24	M24	210	170	51	48	28	25	90	106	81	95	16	14
355 LK ₋ ³⁾	2	725	70	70	M20	M20	140	140	42	40	20	20	62.5	74.5	62.5	74.5	12	12
	4-12	725	100	90	M24	M24	210	170	51	48	28	25	90	106	81	95	16	14
400 L ₋	2	814	80	70	M20	M20	170	140	42	40	22	20	71	85	67.5	79.5	14	12
	4-12	814	110	90	M24	M24	210	170	50	48	28	25	100	106	81	95	16	14
400 LK ₋ ³⁾	2	814	80	70	M20	M20	170	140	42	40	22	20	71	85	67.5	79.5	12	12
	4-12	814	100	90	M24	M24	210	170	50	48	28	25	90	126	81	95	16	14

Motor size	Poles	HB ¹⁾	HB ²⁾	L	LA	LB	LC	LD	M	N	O	P	S	T
355 SM ₋	2	589	603	1409	25	1269	1559	397	740	680	130	800	23	6
	4-12	589	603	1479	25	1269	1659	467	740	680	130	800	23	6
355 ML ₋	2	589	603	1514	25	1374	1664	397	740	680	130	800	23	6
	4-12	589	603	1584	25	1374	1764	467	740	680	130	800	23	6
355 LK ₋ ³⁾	2	589	603	1764	25	1624	1914	397	740	680	130	800	23	6
	4-12	589	603	1834	25	1624	2014	467	740	680	130	800	23	6
400 L ₋	2	-	645	1851	26	1681	2001	458	940	880	150	1000	28	6
	4-12	-	645	1891	26	1681	2071	498	940	880	150	1000	28	6
400 LK ₋ ³⁾	2	-	645	1851	26	1681	2001	458	740	680	150	800	24	6
	4-12	-	645	1891	26	1681	2071	498	740	680	150	800	24	6

¹⁾ Terminal box 370

²⁾ Terminal box 750

³⁾ Size with alternative dimensions

Tolerances:

D, DA ISO m6

N ISO js6 (315₋)

F, FA ISO h9

Above table gives the main dimensions in mm.

For detailed drawings please see our web-pages www.abb.com/motors&drives or contact us.

LV Process performance cast iron motors Sizes 355-400

Dimension drawings

Foot- and flange-mounted: IM B35 (IM 2001), IM V15 (IM 2011), IM V36 (IM 2031)

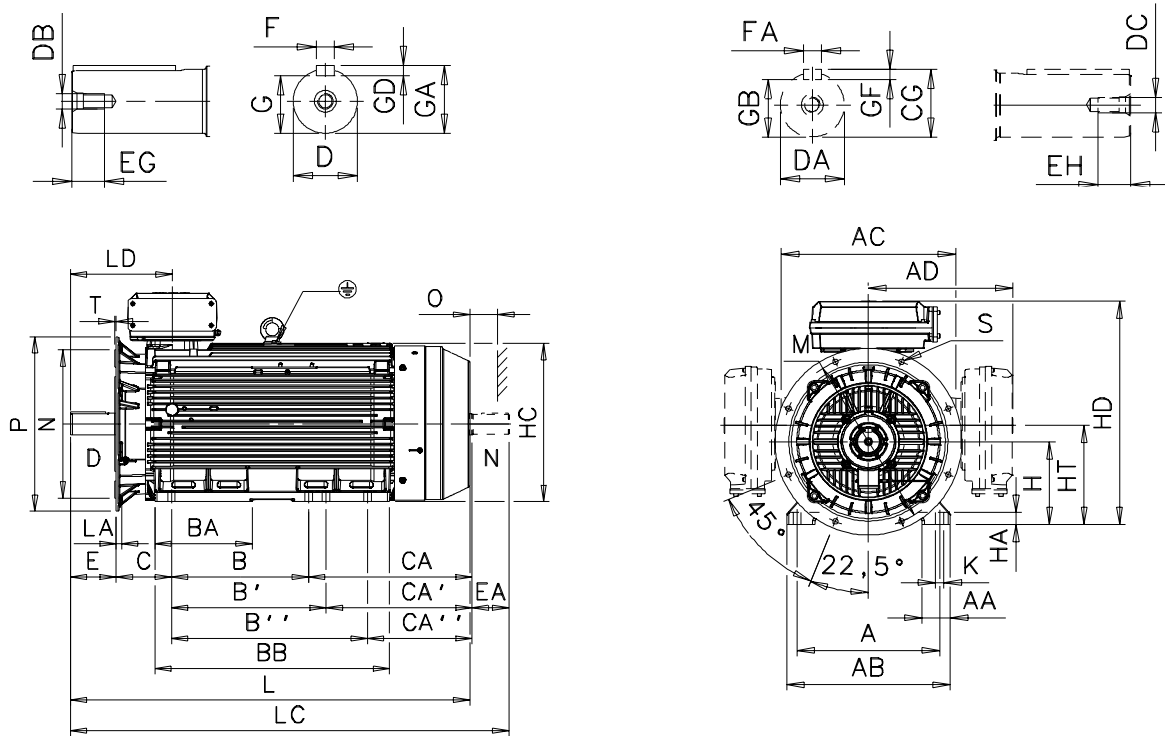

2

Motor size	Poles	A	AA	AB	AC	AD ¹⁾	AD ²⁾	B	B'	B''	BA	BB	C	CA	CA'	CA''	D	DA	DB	DC	E	EA	EG	EH	F	FA	G
355 SM ₂	2	610	120	700	746	604	618	500	560	-	221	722	254	525	465	-	70	70	M20	M20	140	140	42	40	20	20	62.5
	4-12	610	120	700	746	604	618	500	560	-	221	722	254	525	465	-	100	90	M24	M24	210	170	51	48	28	25	90
355 ML ₂	2	610	120	700	746	604	618	560	630	-	267	827	254	500	570	-	70	70	M20	M20	140	140	42	40	20	20	62.5
	4-12	610	120	700	746	604	618	560	630	-	267	827	254	500	570	-	100	90	M24	M24	210	170	51	48	28	25	90
355 LK ₃₎	2	610	120	700	746	604	618	630	710	900	447	1077	254	750	670	480	70	70	M20	M20	140	140	42	40	20	20	62.5
	4-12	610	120	700	746	604	618	630	710	900	447	1077	254	750	670	480	100	90	M24	M24	210	170	51	48	28	25	90
400 L ₂	2	710	150	840	834	-	660	900	1000	-	410	1156	224	701	611	511	80	70	M20	M20	170	140	42	40	22	20	71
	4-12	710	150	840	834	-	660	900	1000	-	410	1156	224	701	611	511	110	90	M24	M24	210	170	50	48	28	25	100
400 LK ₃₎	2	686	150	840	834	-	660	710	800	900	410	1156	280	701	611	511	80	70	M20	M20	170	140	42	40	22	20	71
	4-12	686	150	840	834	-	660	710	800	900	410	1156	280	701	611	511	100	90	M24	M24	210	170	50	48	28	25	90

Motor size	Poles	GA	GB	GC	GD	GF	H	HA	HC	HD ¹⁾	HD ²⁾	HD	K	L	LA	LC	LD	LD	M	N	O	P	S	T
										top-m.	top-m.	side-m.					top-m.	side-m.						
355 SM ₂	2	74.5	62.5	74.5	12	12	355	52	725	944	958	843	35	1409	25	1559	397	679	740	680	130	800	23	6
	4-12	106	81	95	16	14	355	52	725	944	958	843	35	1479	25	1659	467	750	740	680	130	800	23	6
355 ML ₂	2	74.5	62.5	74.5	12	12	355	52	725	944	958	843	35	1514	25	1664	397	732	740	680	130	800	23	6
	4-12	106	81	95	16	14	355	52	725	944	958	843	35	1584	25	1764	467	802	740	680	130	800	23	6
355 LK ₃₎	2	74.5	62.5	74.5	12	12	355	52	725	944	958	843	35	1764	25	1914	397	857	740	680	130	800	23	6
	4-12	106	81	95	16	14	355	52	725	944	958	843	35	1834	25	2014	467	927	740	680	130	800	23	6
400 L ₂	2	85	67.5	79.5	14	12	400	45	812	-	1045	943	35	1851	26	2001	458	909	940	880	150	1000	28	6
	4-12	106	81	95	16	14	400	45	812	-	1045	943	35	1891	26	2071	498	949	940	880	150	1000	28	6
400 LK ₃₎	2	85	67.5	79.5	12	12	400	45	773	-	1045	943	35	1851	26	2001	458	909	740	680	150	800	24	6
	4-12	126	81	95	16	14	400	45	773	-	1045	943	35	1891	26	2071	498	949	740	680	150	800	24	6

¹⁾ Terminal box 370

²⁾ Terminal box 750

³⁾ Size with alternative dimensions

Tolerances:

A, B ± 0,8

D, DA ISO m6

F, FA ISO h9

H +0 -1.0

N ISO js6

C ± 0,8

Above table gives the main dimensions in mm.

For detailed drawings please see our web-pages 'www.abb.com/motors&drives' or contact us.

Dimension drawings

LV Process performance cast iron motors

Terminal boxes, standard design with 6 terminals

Motor sizes 71 - 132

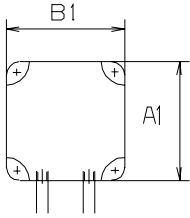

Motor sizes 160 - 250

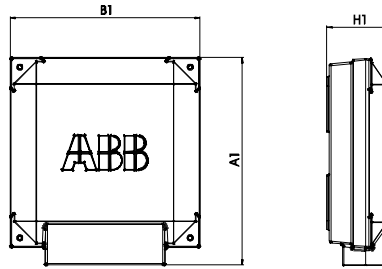

Motor size	A1	B1	H1
71 - 90	124	114	58
100 - 132	134	124	68
160 - 180	240	220	79.5
200 - 250	347.5	310	140.9

2

Motor sizes 280-315 Top- and side-mounted Terminal boxes 210, 370

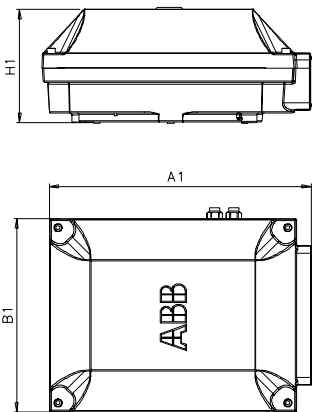

Motor sizes 355-400 Top-mounted Terminal box 750 + adapter

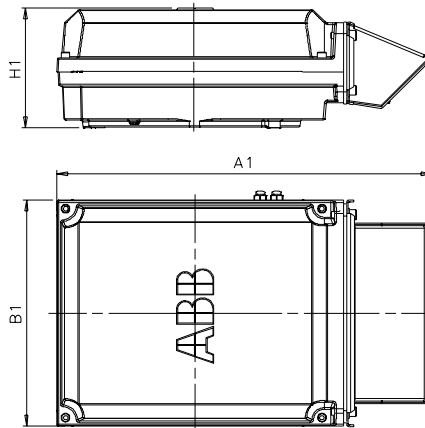

Side-mounted Terminal box 750

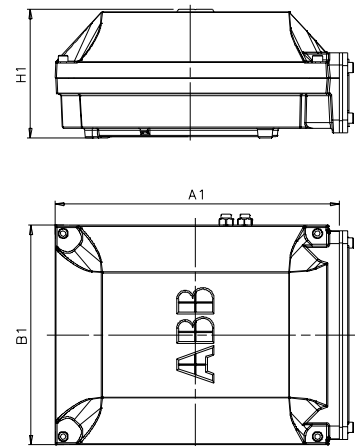

Motor sizes 280 - 400 Terminal box type	A1	B1	H1
210	416	306	177
370	451	347	200
750 top-mounted	686	413	219
750 side-mounted	525	413	219

For motor dimensions please see dimension drawings on earlier pages or on our web-pages www.abb.com/motors&drives.

Accessories

Built-on-brake (variant code 412)

Brake design

Electromagnetic disc brakes are applied by the action of a set of springs and are released when voltage is applied to the brake coil.

This means that the motor will brake automatically in case of any voltage failure, as significant safety feature. The brake is always functional, irrespective of the mounting position of the brake motor.

Detailed view

1. Connection box, (with rectifier, optional)
2. Manual release (optional)
3. Modified N-end shield
4. V-ring seal
5. Adapter flange for brake
6. Brake
7. V-ring seal
8. Fan cover
9. Fan

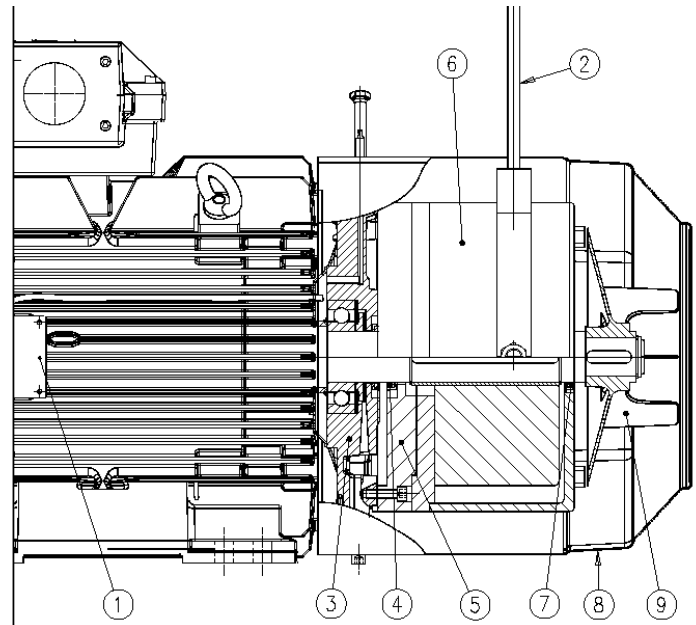

Brake disc

The brake linings are made from asbestos-free material. The linings are highly resistant to wear and have excellent thermal conductivity, giving consistent performance across the temperature range. The brake disc withstands large number of braking operations and is insensitive to dust and moisture. Please note that changing between a used and a new disc will result in a different braking torque.

Replacing the brake disc

The brake disc must be replaced when reaching the minimum permissible lining thickness stated; please see the data provided by the brake manufacturer.

Rectifier

The rectifier is a device for DC brake applications. It is highly resistant to temperature as well as to voltage peaks, and it includes an additional protection of the auxiliary contact of contactor. With a compact design, it can be placed inside the motor terminal box. Since the rectifier is optional, please state this option when ordering if required.

Torque adjustment

Reducing the torque of the brake is possible with most brake types, please see manufacturer's catalogue or contact ABB for more information.

Manual release

The manual release has two options, it either comes with screws (standard) or with a manual release. The manual release overrides the action of the brake springs as long as it is applied. Manual release is an option available for all motor sizes, however it cannot be used in combination with the Pintsch Bamag brakes type SFB.

Brake rating plates

The same brake rating plates are used as for the standard M3BP motors i.e. stainless steel, with an additional marking of code 412, which stands for 'built-on-brake'.

Available brake types

The motors available in this section can be fitted with recommended brakes from either Pintsch Bamag or Stromag according to the table below; other brakes can be ordered on request.

Pintsch & Bamag, type KFB, IP 67, 110 V DC

Electromagnetic Double-Disc Spring-Applied Brake

Brake type	Brake torque Nm	For motor size
KFB 10	100	160
KFB 16	160	160 - 180
KFB 25	250	180 - 225
KFB 40	400	200 - 250
KFB 63	630	225 - 280
KFB 1000	1000	280 - 315
KFB 1600	1600	315 - 355
On request		355 - 400

Pintsch & Bamag, type SFB, IP 67, 110 V DC

Electromagnetic Double-Disc Spring-Applied Brake

Brake type	Brake torque Nm	For motor size
SFB 16	160	200 - 225
SFB 25	250	200 - 250
SFB 40	400	225 - 250
SFB 63	630	250
SFB 100	1000	280 - 315
SFB 160	1600	315 - 355
SFB 250	2500	355 - 400
SFB 400	4000	400

Stromag, type NFF, 110 V DC, IP66

Brake type	Brake torque Nm	For motor size
NFF 10	100	160
NFF 16	160	160 - 180
NFF 25	250	180 - 225
NFF 40	400	200 - 250
NFF 63	630	225 - 250

Options for the brake

On new manufacture only

- Hand release (not possible for Pintsch Bamag brake type SFB)
- Rectifier
- Micro switch
- Proximity switch (not possible for Stromag brake)
- Standstill heater

On request

- Special brake voltage
- Raised brake torque
- Combination with brake, separate cooling fan and/or tacho

For other variants, please contact ABB.

Dimensions of brake motor

Foot-mounted:

IM B3 (IM1001), IM B6 (IM 1051), M B7 (IM1061), IM B8 (IM 1071), IM V5 (IM 1011), IM V6 (IM 1031)

Flange-mounted:

IM B5 (IM 3001) , IM V1 (IM 3011), IM V3 (IM 3031), IM B14 (IM 3601), IM V18 (IM 3611), IM V19 (IM 3631)

Foot- and flange-mounted:

IM B35 (IM 2001), IM V15 (IM 2011), IM V36 (IM 2031)

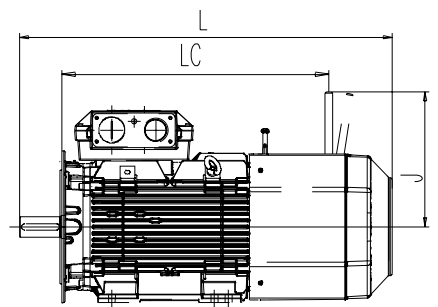
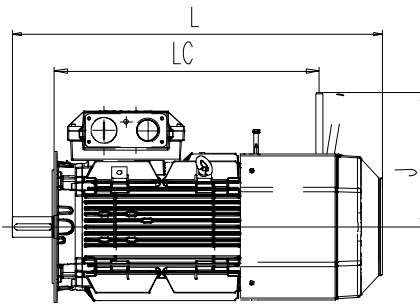
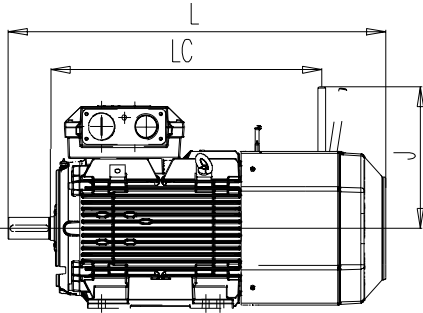

Motor size	Poles	Foot-mounted			Flange-mounted			Foot- and flange-mounted		
		L	LC	J	L	LC	J	L	LC	J
160	2-8	834	587	356	834	587	356	834	587	356
180	2-8	910	637	372	910	637	372	910	637	372
200ML	2-8	994	684	432	994	684	432	994	684	432
225SM	2	1071	754	460	1071	754	460	1071	754	460
225SM	4-8	1101	754	460	1101	754	460	1101	754	460
250SM	2-8	1110	761	460	1110	761	460	1110	761	460

Motor sizes 280-400 on request.

Other dimensions same as process performance cast iron motors sizes 180 to 250.



Accessories

Protective roof and variable speed drives

Protective roof

Variant code 005

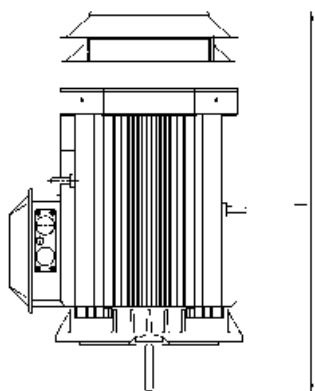

Tacho

Variant codes; 472, 473, 572 and 573

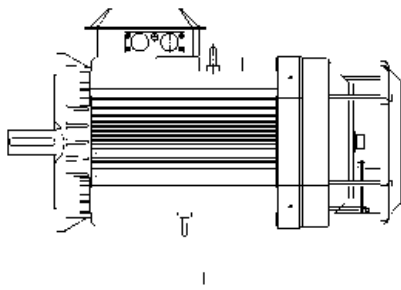

Separate cooling with or without tacho

Variant codes; 183, 474, 476, 477, 189, 574, 576 and 577

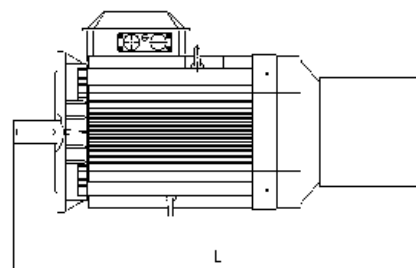

Variant codes;		005	183	189	472,473 572,573	474,476 477,574 576,577
Motor size	Pole no	L	L	L	L	L
160 ¹⁾	2-8	654.5	1015.5	870.5	697	1015.5
160 ²⁾	2-8	695.5	1056.5	911.5	738	1056.5
180 ³⁾	2-8	732	1097	952	774	1097
180 ⁴⁾	2-8	752.5	1117.5	972.5	795	1117.5
200ML_	2-8	826.5	1234	1089	868	1234
225SM_	2	887	1295	1150	930	1295
	4-8	918	1325	1180	960	1325
250SM_	2-8	952	1346	1201	969	1346
280SM_	2	1190	1472	NA	1184	1620
	4-12	1190	1472	NA	1184	1620
315SM_	2	1290	1552	NA	1268	1708
	4-12	1320	1582	NA	1298	1738
315ML_	2	1400	1662	NA	1378	1820
	4-12	1430	1692	NA	1408	1850
315LK_	2	1561	1920	NA	1584	2054
	4-12	1591	1950	NA	1614	2084
355SM_	2	1513	1835	NA	1504	1963
	4-12	1583	1905	NA	1574	2033
355ML_	2	1618	1986	NA	1609	2119
	4-12	1688	2056	NA	1679	2189
355LK_	2	1881	2236	NA	1899	2409
	4-12	1951	2306	NA	1929	2439
400L/LK	2	1968	2313	NA	1946	2435
	4-12	2008	2353	NA	1986	2475

¹⁾ M-2, MA-2, M-4, M-6, M-8, MA-8, L-2, L-4, L-6, MA-2/4, M-2/4, L-2/4, M-4/6, M-4/8, LB-2, LB-4

²⁾ L-8, L-4/6, L-4/8, LB-6, LB-8.

³⁾ M-2, M-4, L-6, L-8, M-2/4, M-4/6, M-4/8, LB-2.

⁴⁾ L-2/4, L-4/6, L-4/8, L-4, LB-4, LB-6, LB-8.

Accessories

Silencer for LV process performance cast iron motor sizes 280-400

Both foot-mounted and flange-mounted motors can be fitted with a silencer to reduce the noise level by about 10 dB(A). The silencer is painted blue and is made of 2 mm steel sheet. The sound absorbing material is 40 mm thick polyurethane foam. On the underside there is a rubber strip to seal against the floor. The silencer fits loosely over the motor.

Dimensions of silencers for foot-mounted motors

Silencers for flange-mounted motors on request.

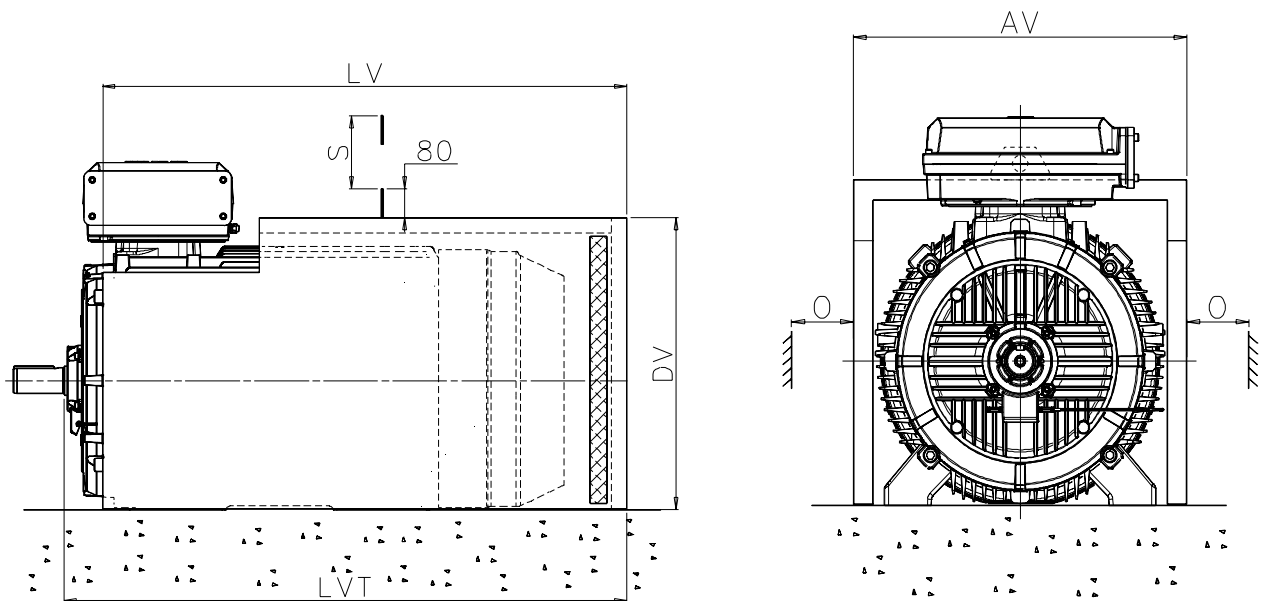

2

Motor size	AV	LV	LVT	DV	O ¹⁾	S ²⁾	Weight kg
280SM_	681	1010	1090	616	50	762	38
315SM_	760	1094	1191	697	60	852	47
315ML_	760	1205	1302	697	60	852	51
315LK_	760	1411	1508	697	60	852	58
355SM_	850	1335	1441	777	65	958	62
355ML_	850	1440	1546	777	65	958	67
355LK_	850	1690	1796	777	65	958	77
400L_	938	1750	1873	866	75	1045	88
400LK_	938	1750	1873	866	75	1045	88

¹⁾ Clearance for motor cooling.

²⁾ Clearance for removal of silencer.

Note: Dimensions of silencers for smaller frame sizes on request.

LV Process performance cast iron motor construction

Typical exploded view of cast iron motors, frame size 315

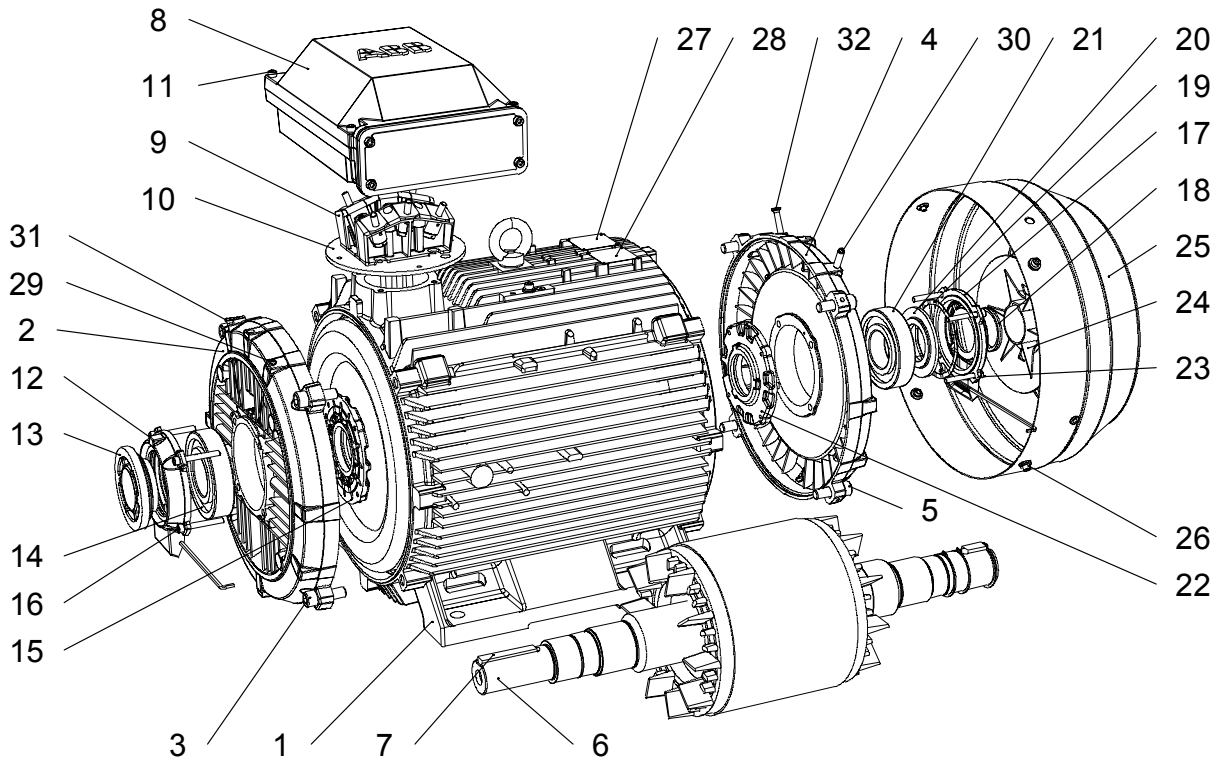

- | | | | |
|----|--|----|---------------------------------|
| 1 | Stator frame | 17 | Outer bearing cover, N-end |
| 2 | Endshield, D-end | 18 | Seal, N-end |
| 3 | Screws for endshield, D-end | 19 | Wave spring |
| 4 | Endshield, N-end | 20 | Valve disc, N-end |
| 5 | Screws for endshield, N-end | 21 | Bearing, N-end |
| 6 | Rotor with shaft | 22 | Inner bearing cover, N-end |
| 7 | Key, D-end | 23 | Screws for bearing cover, N-end |
| 8 | Terminal box | 24 | Fan |
| 9 | Terminal board | 25 | Fan cover |
| 10 | Intermediate flange | 26 | Screws for fan cover |
| 11 | Screws for terminal box cover | 27 | Rating plate |
| 12 | Outer bearing cover, D-end | 28 | Regreasing plate |
| 13 | Valve disc with labyrinth seal, D-end;
standard in 2-pole motors (V-ring in 4-8 pole) | 29 | Grease nipple, D-end |
| 14 | Bearing, D-end | 30 | Grease nipple, N-end |
| 15 | Inner bearing cover, D-end | 31 | SPM nipple, D-end |
| 16 | Screws for bearing cover, D-end | 32 | SPM nipple, N-end |

LV Process performance cast iron motors in brief, basic design

Motor size		71	80	90	100	112	132	160	180
Stator	Material	Cast iron EN-GJL-200/GG 20/GRS 200							
	Paint colour shade	Blue, Munsell 8B 4.5/3.25 / NCS 4822 B05G							
	Paint thickness	Two-pack PUR-paint, thickness $\geq 60 \mu\text{m}$						Two-pack epoxy paint, thickness $\geq 70 \mu\text{m}$	
Bearing end shields	Material	Cast iron EN-GJL-150/GG 15/GRS 150				Cast iron EN-GJL-150/GG 15/GRS 150, flange end shields GJL-200			
	Paint colour shade	Blue, Munsell 8B 4.5/3.25 / NCS 4822 B05G							
	Paint thickness	Two-pack PUR-paint, thickness $\geq 60 \mu\text{m}$						Two-pack epoxy paint, thickn. $\geq 70 \mu\text{m}$	
Bearings	D-end = N-end	6202 2RS C3	6204 2RS C3	6205 2RS C3	6206 2RS C3	6207 2RS C3	6208 2RS C3	6309/C3	6310/C3
	N-end	6202 2RS C3	6204 2RS C3	6205 2RS C3	6206 2RS C3	6206 2RS C3	6207 2RS C3	6309/C3	6309/C3
Axially-locked bearings	Inner bearing cover	As standard, locked at D-end							
Bearing seal		2RS-integral seals						Axial seal as standard, radial seal on request	
Lubrication		Greased for life						Regreasable bearings, regr.nipples M6x1	
SPM-nipples		-						As standard	
Rating plate	Material	Stainless steel 0.80 Cr 18 Ni9						Stainless steel, SS-EN 10088, 0.5mm	
Terminal box	Frame material	Cast iron EN-GJL-150/GG 15/GRS 150							
	Cover material	Cast iron EN-GJL-150/GG 15/GRS 150							
	Cover screws material	Steel 5G, coated with zinc and yellow cromated							
Connections	Cable entries	2xM16	2xM25	2xM25	2xM32	2xM32	2xM32	2xM40	2xM40
	Terminals	6 terminals for connection with cable lugs (not included)							
	Cable glands	Available as option						Cable flanges as std, cable glands as option	
Fan	Material	Glass fibre reinforced plastic							
Fan cover	Material	Steel							
	Paint colour shade	Blue, Munsell 8B 4.5/3.25 / NCS 4822 B05G							
	Paint thickness	Two-pack PUR-paint, thickness $\geq 60 \mu\text{m}$						Two-pack polyester powder paint, thickness $\geq 50 \mu\text{m}$	
Stator winding	Material	Copper							
	Insulation	Insulation class F							
	Winding protection	3 PTC thermistors as standard, 150°C							
Rotor winding	Material	Pressure die-cast aluminum							
Balancing method		Half key balancing as standard							
Key ways		Open key way						Closed key way	
Heating elements	On request	25 W	25 W	25 W	25 W	25 W	25 W	25 W	25 W
Drain holes		Optional						Standard	
Enclosure		IP 55, higher protection on request							
Cooling method		IC 411							

LV Process performance cast iron motors in brief, basic design

Motor size		200	225	250	280	315	355	400
Stator	Material	Cast iron EN-GJL-200/GG 20/GRS 200						
	Paint colour shade	Blue, Munsell 8B 4.5/3.25 / NCS 4822 B05G						
	Paint thickness	Two-pack epoxy paint, thickness $\geq 70 \mu\text{m}$						
Bearing end shields	Material	Cast iron EN-GJL-150/GG 15 GRS150, flange end shields GLJ-200			Cast iron EN-GJL200/GG20/GRS 200, EN-GLJ-250 /GG25/GRS 250, EN-GJS-400/GGG40/GRP 400			
	Paint colour shade	Blue, Munsell 8B 4.5/3.25 / NCS 4822 B05G						
	Paint thickness	Two-pack epoxy paint, thickness $\geq 70 \mu\text{m}$						
Bearings	D-end 2-pole 4-12 -pole	6312/C3	6313/C3	6315/C3	6316/C3 6316/C3	6316/C3 6319/C3	6316M/C3 6322/C3	6317M/C3 6324/C3
	N-end 2-pole 4-12 -pole	6310/C3	6312/C3	6313/C3	6316/C3 6316/C3	6316/C3 6316/C3	6316M/C3 6316/C3	6317M/C3 6319/C3
Axially-locked bearings	Inner bearing cover	As standard, locked at D-end						
Bearing seals		Axial seal as standard, radial seal on request			V-ring or labyrinth seal as standard see table in page 19.			
Lubrication		Regreasable bearings, regreasing nipples M6x1			Regreasable bearings, regreasing nipples, M10x1			
SPM-nipples		As standard						
Rating plate	Material	Stainless steel, EN 10088, thickness 0.5 mm						
Terminal box	Frame material	Cast iron EN-GJL150/GG 15/GRS 150			Cast iron EN-GJL-250/GG 25/GRS 250			
	Cover material Cover screws material	Cast iron EN-GJL150/GG 15/GRS 150 Steel 8.8, zinc electroplated and yellow chromated			Cast iron EN-GJL-250/GG 25/GRS 250			
Connections	Cable-entries 2-, 4-pole 6-pole	2xM63	2xM63	2xM63	2xM63	*)2xM63	*)2xØ60/80 *)2xØ60	*)2xØ80 *)2xØ60/80
	Terminals	6 terminals for connection with cable lugs (not included)						
	Cable glands	Cable flanges as standard, cable glands as option			Cable glands included as standard			
Fan	Material	Glass fibre reinforced plastic			Glass fibre reinforced plastic or aluminum			
Fan cover	Material	Steel						
	Paint colour shade	Blue, Munsell 8B 4.5/3.25 / NCS 4822 B05G						
	Paint thickness	Two-pack polyester powder paint, thickness $\geq 50 \mu\text{m}$			Two-pack epoxy polyester powder paint, thickness $\geq 80 \mu\text{m}$			
Stator winding	Material	Copper						
	Insulation	Insulation class F						
	Winding protection	3 PTC thermistors as standard, 150°C			3 PTC thermistors as standard, 155°C			
Rotor winding	Material	Pressure die-cast aluminum						
Balancing method		Half key balancing as standard						
Key way		Closed key way			Open key way			
Heating elements	On request	50 W	50 W	50 W	50 W	2x50 W	2x65 W	2x65 W
Drain holes		Standard, open on delivery						
Enclosure		IP 55, higher protection on request						
Cooling method		IC 411						

*) For detailed information of connections, please see page 16.

ABB Motors' total product offer

ABB offers several comprehensive ranges of AC motors and generators. We manufacture synchronous motors for even the most demanding applications, and a full range of low and high voltage induction motors. Our in-depth knowledge of virtually every type of industrial processing ensures we always specify the best solution for your needs.

Low voltage motors and generators

General purpose motors for standard applications

- Aluminum motors
- Steel motors
- Cast iron motors
- Open drip proof motors
- Brake motors
- Single phase motors
- Integral motors

Process performance motors for more demanding applications

- Aluminum motors
- Cast iron motors

Other applications

- Motors for hazardous areas
- Marine motors
- Permanent magnet motors
- High speed motors
- Wind turbine generators
- NEMA motors
- Water cooled motors
- Motors for roller table drives
- Slip ring motors
- Wood dryer motors
- Fan application motors

High voltage and synchronous motors and generators

- High voltage cast iron motors
- Induction modular motors
- Slip ring motors
- Motors for hazardous areas
- Servomotors
- Synchronous motors and generators
- DC motors and generators

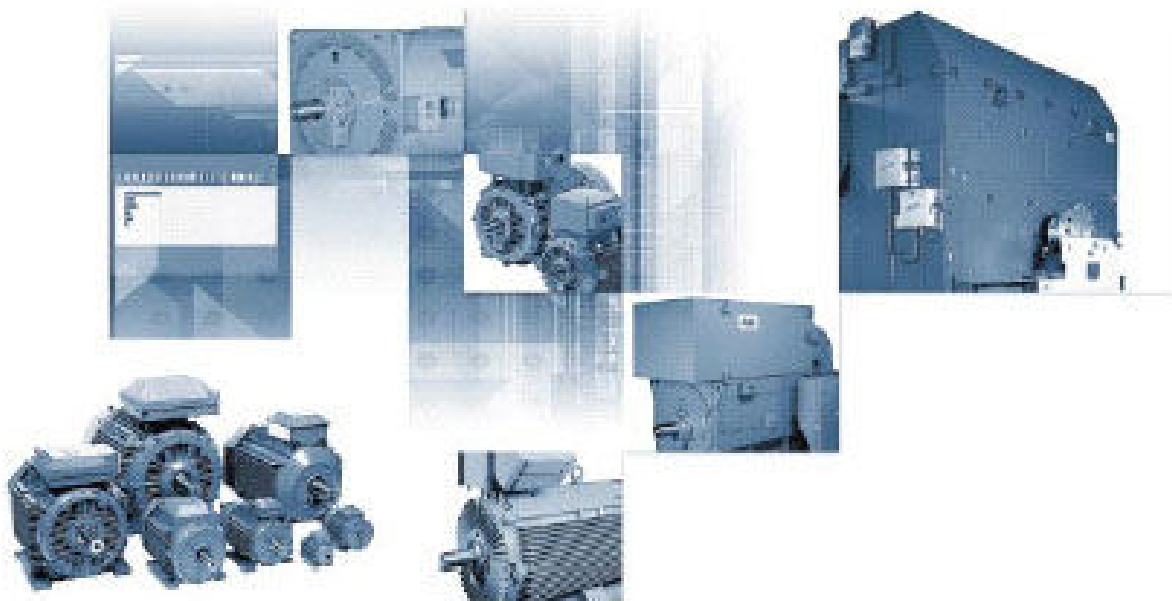

Visit our web site

www.abb.com/motors&drives

Motors & Drives

- => Low Voltage Motors
- => Range of Products
 - General purpose motors
 - Aluminum motors
 - Steel motors
 - Cast iron area motors
 - Open drip proof motors
 - Brake motors
 - Single phase motors
 - Integral motors
- => **Process performance motors**
 - Cast iron motors
 - Aluminum motors
 - Motors for hazardous areas
 - Marine motors
 - Roller table motors
 - Water cooled motors
 - Permanent magnet motors
 - High speed motors
 - Wind turbine generators
- Library of documents
- => Technical documents
- Local contacts

Drive^{IT} Low Voltage Motors

Manufacturing sites (*) and some of the larger sales companies.

Australia

ABB Industry Pty Ltd
2 Douglas Street
Port Melbourne,
Victoria, 3207
Tel: +61 (0) 3 9644 4100
Fax: +61 (0) 3 9646 9362

Austria

ABB AG
Wienerbergstrasse 11 B
AT-1810 Wien
Tel: +43 (0) 1 601 090
Fax: +43 (0) 1 601 09 8305

Belgium

Asea Brown Boveri S.A.-N.V.
Hoge Wei 27
BE -1930 Zaventem
Tel: +32 (0) 2 718 6311
Fax: +32 (0) 2 718 6657

Canada

ABB Inc., BA Electrical Machines
10300 Henri-Bourassa Blvd,
West, Saint-Laurent, Quebec
Canada H4S 1N6
Tel: +1 514 832-6583
Fax: +1 514 332-0609

China*

ABB Shanghai Motors
Company Limited
8 Guang Xing Rd., Rong Bei
Town, Songjiang County,
Shanghai 201613
Tel: +86 21 5778 0988
Fax: +86 21 5778 1364

Chile

Asea Brown Boveri S.A.
P.O.Box 581-3
Santiago
Tel: +56 (0) 2 5447 100
Fax: +56 (0) 2 5447 405

Denmark

ABB A/S
Automation Technology Electrical
Machines
Petersmindevej 1
DK-5000 Odense C
Tel: +45 65 477 070
Fax: +45 65 477 713

Finland*

ABB Oy
LV Motors
P.O.Box 633
FI-65101 Vaasa
Tel: +358 (0) 10 22 11
Fax: +358 (0) 10 22 47372

France

ABB Automation
Rue du Général de Gaulle
Champagne-sur-Seine
FR-77811 Moret-sur-Loing Cedex
Tel: +33 (0) 1 60 746 500
Fax: +33 (0) 1 60 746 565

Germany

ABB Automation Products GmbH
Edisonstrasse 15
DE-68623 Lampertheim
Tel: +49 (0) 6206 503 503
Fax: +49 (0) 6206 503 600

Hong Kong

ABB (Hong Kong) Ltd.
Tai Po Industrial Estate,
3 Dai Hei Street,
Tai Po, New Territories,
Hong Kong
Tel: +852 2929 3838
Fax: +852 2929 3505

India*

ABB Ltd.
32, Industrial Area, N.I.T
Faridabad 121 001
Tel: +91 (0) 129 502 3001
Fax: +91 (0) 129 502 3006

Indonesia

PT. ABB Sakti Industri
JL. Gajah Tunggal Km.1
Jatiuwung, Tangerang 15136
Banten, Indonesia
Tel: + 62 21 590 9955
Fax: + 62 21 590 0115 - 6

Ireland

Asea Brown Boveri Ltd
Components Division
Belgard Road
Tallaght, Dublin 24
Tel: +353 (0) 1 405 7300
Fax: +353 (0) 1 405 7327

Italy*

ABB SACE SpA
LV Motors
Via Della Meccanica, 22
IT-20040 Caponago - MI
Tel: +39 02 959 6671
Fax: +39 02 959 667216

Japan

ABB K.K.
26-1 Cerulean Tower
Sakuragaoka-cho, Shibuya-ku
Tokyo 150-8512
Tel: +81 (0) 3 578 46251
Fax: +81 (0) 3 578 46260

Korea

ABB Korea Ltd.
7-9fl, Oksan Bldg., 157-33
Sungshung-dong, Kangnam-ku
Seoul
Tel: +82 2 528 2329
Fax: +82 2 528 2338

Malaysia

ABB Malaysia Sdn. Bhd.
Lot 608, Jalan SS 13/1K
47500 Subang Jaya, Selangor
Tel: +60 3 5628 4888
Fax: +60 3 5631 2926

Mexico

ABB México, S.A. de C.V.
Apartado Postal 111
CP 54000 Tlalnepantla
Edo. de México, México
Tel: +52 5 328 1400
Fax: +52 5 390 3720

The Netherlands

ABB B.V.
Dept. LV motors (APP2R)
P.O.Box 301
NL-3000 AH Rotterdam
Tel: +31 (0) 10 4078 879
Fax: +31 (0) 10 4078 345

Norway

ABB AS
Automation Technology Products
Division
P.O.Box 6540 Rodeloekka
NO-0501 Oslo 5
Tel: +47 22 872 000
Fax: +47 22 872 541

Singapore

ABB Industry Pte Ltd
2 Ayer Rajah Crescent
Singapore 139935
Tel: +65 6776 5711
Fax: +65 6778 0222

Spain*

ABB Automation Products S.A.
Division Motores
P.O.Box 81
ES-08200 Sabadell
Tel: +34 93 728 8500
Fax: +34 93 728 8741

Sweden*

ABB Automation Technologies AB
LV Motors
SE-721 70 Västerås
Tel: +46 (0) 21 329 000
Fax: +46 (0) 21 124 103

Switzerland

ABB Schweiz AG
Normelec
Badenerstrasse 790
Postfach
CH-8048 Zürich
Tel: +41 (0) 58 586 0000
Fax: +41 (0) 58 586 0603

Taiwan

ABB Ltd.
6F, No. 126, Nanking East
Road, Section 4i
Taipei, 105 Taiwan, R.O.C.
Tel: +886 (0) 2 2577 6090
Fax: +886 (0) 2 2577 9467

Thailand

ABB Limited (Thailand)
161/1 SG Tower,
Soi Mahadlekluang 3,
Rajdamri, Bangkok 10330
Tel: +66 2 665 1000
Fax: +66 2 6042

The United Kingdom

ABB Automation Ltd
9 The Towers, Wilmslow Road
Didsbury
Manchester, M20 2AB
Tel: +44 (0) 161 445 5555
Fax: +44 (0) 161 448 1016

USA

ABB Inc.
Electrical Machines
P.O.Box 372
Milwaukee
WI 53201-0372
Tel: +1 262 785 3200
Fax: +1 262 785 8628

Venezuela

Asea Brown Boveri S.A.
P.O.Box 6649
Carmelitas,
Caracas 1010A
Tel: +58 (0) 2 238 2422
Fax: +58 (0) 2 239 6383

